



ENERGY KING WOOD/COAL FURNACE

Models EK365, EK385 and EK480



Installation, Operation & Maintenance Manual

Energy King
325 South Park St.
Reedsburg, WI 53959
800-944-2516
www.EnergyKing.com



ENERGY KING® Wood/Coal Furnaces

Installation and Operating Instructions

Models EK365, EK385 and EK480

Congratulations on your purchase of an ENERGY KING solid fuel heating appliance!

Your ENERGY KING Wood/Coal Furnace is designed for a lifetime of durable, reliable performance and easy operation. This manual describes the installation, operation and maintenance of your ENERGY KING Wood/Coal Furnace.

Save these instructions.

Before installing your ENERGY KING Wood/Coal Furnace, please read and be sure you understand the entire owner's manual and safety instructions.

Refer to markings on the appliance for additional instructions.

ENERGY KING Wood/Coal Furnace has been designed to use independently or as an add-on to an existing central heating system. The installation of any furnace ***is not a do-it-yourself project***. To ensure the ENERGY KING Wood/Coal Furnace will operate safely and efficiently, the **installation must be performed by a qualified installer with specific knowledge of central heating systems.**

With proper installation and maintenance, your ENERGY KING Wood/Coal Furnace will give you years of trouble free service.

Thank you for choosing the ENERGY KING Wood/Coal Furnace.

We are constantly improving and updating our products in order to provide the highest quality and value possible. Ark Alloy, LLC, the manufacturer of this product, reserves the right to alter its products, their specifications and/or prices without notice.

Energy King
325 South Park St.
Reedsburg, WI 53959
800-944-2516
www.energyking.com

Email: info@energyking.com

ENERGY KING is a registered trademark of Ark Alloy, LLC



Failure to follow these safety instructions may result in property damage, bodily injury or even death.

▲ Read this entire manual before installing, operating or maintaining this product. Proper installation of this heating appliance is crucial for safe and efficient operation. Save these instructions for later use.

▲ ***This heating appliance must be installed in accordance with local, state, and national codes and regulations.***

Contact your local building or fire officials about installation restrictions and inspection requirements in your area.

▲ ***Do not connect this heating appliance to a chimney flue serving any other appliance.***

▲ ***Do not install this heating appliance in a mobile or manufactured home—this can be dangerous and will void your warranty.***

This heating appliance has not been tested to meet the strict requirements necessary for installation into a mobile or manufactured home.

▲ Install in an area with adequate air for combustion and ventilation. The use of outside air may be required for safe operation of this heating appliance. Contact your local building or fire officials about combustion air requirements in your area.

▲ All minimum clearances to combustible materials must be strictly followed.

▲ This heating appliance must be installed on a non-combustible floor or 3/8-inch thick fireproof millboard or equivalent. See *Installation* for further instructions.

▲ Disconnect all power to the heating appliance at the breaker box or service panel before performing routine maintenance and service. Allow the heating appliance to cool before servicing.

▲ The fuel loading and ash removal doors must be closed tightly during operation. All seals must be maintained in good condition.

▲ This Furnace is designed to burn air-dried wood, or anthracite or bituminous coal only. *Burning of any other type of fuel will void your ENERGY KING warranty.*

▲ **Do not burn:** Treated wood, colored paper, garbage, cardboard, solvents, or trash—burning these may result in toxic fumes, or produce soot and large flakes of char or fly ash. *Burning treated wood, colored paper, garbage, cardboard, solvents or trash can be dangerous and will void your ENERGY KING warranty.*

▲ Do not place clothing or other flammable materials on this heating appliance or within marked clearances to combustibles.

▲ Do not use, store, or dispose of flammable liquids near the heating appliance.

▲ **DANGER – Risk of Fire or Explosion:** Do not burn garbage, gasoline, naphtha, drain or engine oil, or other flammable liquids or inappropriate materials in this heating appliance.

▲ Do not use chemicals or fluids, such as gasoline, gasoline-type lantern fuel, kerosene, charcoal lighter fluid, or similar liquids to start or freshen up a fire in this heating appliance.

▲ Establish a routine for the storage of fuel, care of the heating appliance and firing techniques.

▲ **CAUTION – Hot Surfaces:** Keep children away! Do not touch heating appliance during operation.



Safety Instructions

▲ Dispose of ashes with care. Ashes should be placed in a metal container with a tight fitting metal lid. The closed container of ashes should be placed on a noncombustible floor or on the ground, well away from all combustible materials, pending final disposal.

All coal contains small amounts of dangerous elements. Therefore it is essential that all coal be disposed of in municipally designated areas.

▲ Use caution when opening fuel loading door. Opening fuel loading door rapidly can cause smoke or flame to flash out the door. See *Operation* for further instructions.
Rev

▲ A working smoke detector **must** be installed in the same room as this product. For additional safety, Energy King also recommends installing working smoke detectors and a listed carbon monoxide warning device in the living areas of the home.

▲ Always keep a working fire extinguisher on hand in case of fire.

The National Fire Protection Association has information available on the safe use of solid-fuel heating appliances. You can contact the NFPA at: National Fire Protection Association, 1 Battery March Park, Quincy, MA 02169-7471 or www.nfpa.org.



Table of Contents

SAFETY INSTRUCTIONS.....	1
TABLE OF CONTENTS.....	3
SPECIFICATIONS.....	4
COMPONENT DESCRIPTION.....	5
PREINSTALLATION CONSIDERATION.....	7
FUEL REQUIREMENTS.....	8
Wood.....	8
Coal.....	9
INSTALLATION.....	10
General Requirements.....	10
<i>Placement</i>	10
• Floor Protection.....	10
• As Primary Furnace.....	10
• As Add-On Furnace.....	11
Assembling your ENERGY KING Wood/Coal Furnace.....	12
Combustion Air Requirements.....	18
Venting System.....	19
<i>Masonry Chimney</i>	21
<i>Chimney Connector</i>	21
<i>Barometric Draft Control</i>	22
Air Duct Installation.....	23
OPERATION.....	24
General Instructions.....	24
First Fire.....	24
Typical Operation Cycle.....	25
Power Failure Instructions.....	25
Burning Wood.....	26
<i>Starting a Wood Fire</i>	26
<i>Refueling</i>	26
Burning Coal.....	27
<i>Starting a Coal Fire</i>	28
<i>Refueling/Recharging</i>	28
MAINTENANCE.....	30
Creosote – Formation and Need for Removal.....	30
Disposal of Ashes.....	30
Gasket Replacement.....	31
Routine Maintenance.....	31
TROUBLESHOOTING GUIDE.....	33
Detailed Troubleshooting.....	34
APPENDIX A: WIRING DIAGRAMS.....	37
A-1: Automatic Draft Wiring Diagram.....	37
A-2: Forced Air Draft Wiring Diagram.....	38
A-3: Manual Draft Wiring Diagram.....	39
APPENDIX B: FILTER BOX ASSEMBLY SCHEMATIC.....	40
APPENDIX C: PARTS LIST.....	41
APPENDIX D: PURCHASE & SERVICE RECORD.....	42
APPENDIX E: WARRANTY CLAIM PROCEDURES.....	43
LIMITED WARRANTY.....	45
SUPPLEMENT A: 24-V WALL THERMOSTAT.....	47
SUPPLEMENT B: FAN/LIMIT CONTROL.....	53



Specifications

Description	EK365	EK385	EK480
Dimensions (H x W x D)	48" x 26" x 53"	48" x 26.5" x 53"	51.5" x 26" x 60"
Leg Height	3.5"	3.5"	3.5"
Shipping Weight (Approx.)	650 lbs.	875 lbs.	725 lbs.
Heating Capacity – BTU's (Approx.)	125,000 BTU	125,000 BTU	160,000 BTU
Heating Capacity – Sq. Ft (Approx.)	1,500 sq. ft.	2,000 sq. ft.	2,500 sq. ft.
Flue Size (Rear Vent)	6"	6"	6"
Flue Collar Height (to top of flue)	45"	43"	48.25"
Log Length	21"	22"	26"
Cast Iron Fuel Loading Door Size (H x W)	15.5" x 13.5"	15.5" x 13.5"	15.5" x 13.5"
Cast Iron Ash Removal Door Size (H x W)	7.25" x 11.5"	7.25" x 11.5"	7.25" x 11.5"
Sliding Smoke Baffle	Standard	Standard	Standard
Insulated Cabinet	Standard	Standard	Standard
Wall Thermostat	Standard	Standard	Standard
Draft Controls	Manual or Auto (Choice)		
Pre-Wired Electrical Components	Standard	Standard	Standard
Electrical Requirements	115 Volts, 60HZ, 1 Phase, 15 Amps Circuit	115 Volts, 60HZ, 1 Phase, 15 Amps Circuit	115 Volts, 60HZ, 1 Phase, 15 Amps Circuit
Cast Iron Hearth Plates (Front & Rear)	Standard	Standard	Standard
Removable Ash Pan	Standard	Standard	Standard
Cast Iron Stationary (Wood) Grates	Standard	Standard	Standard
Cast Iron Shaker Grates	Optional	Optional	Optional
Domestic Hot Water Tube	Optional	Optional	Optional

Component Description

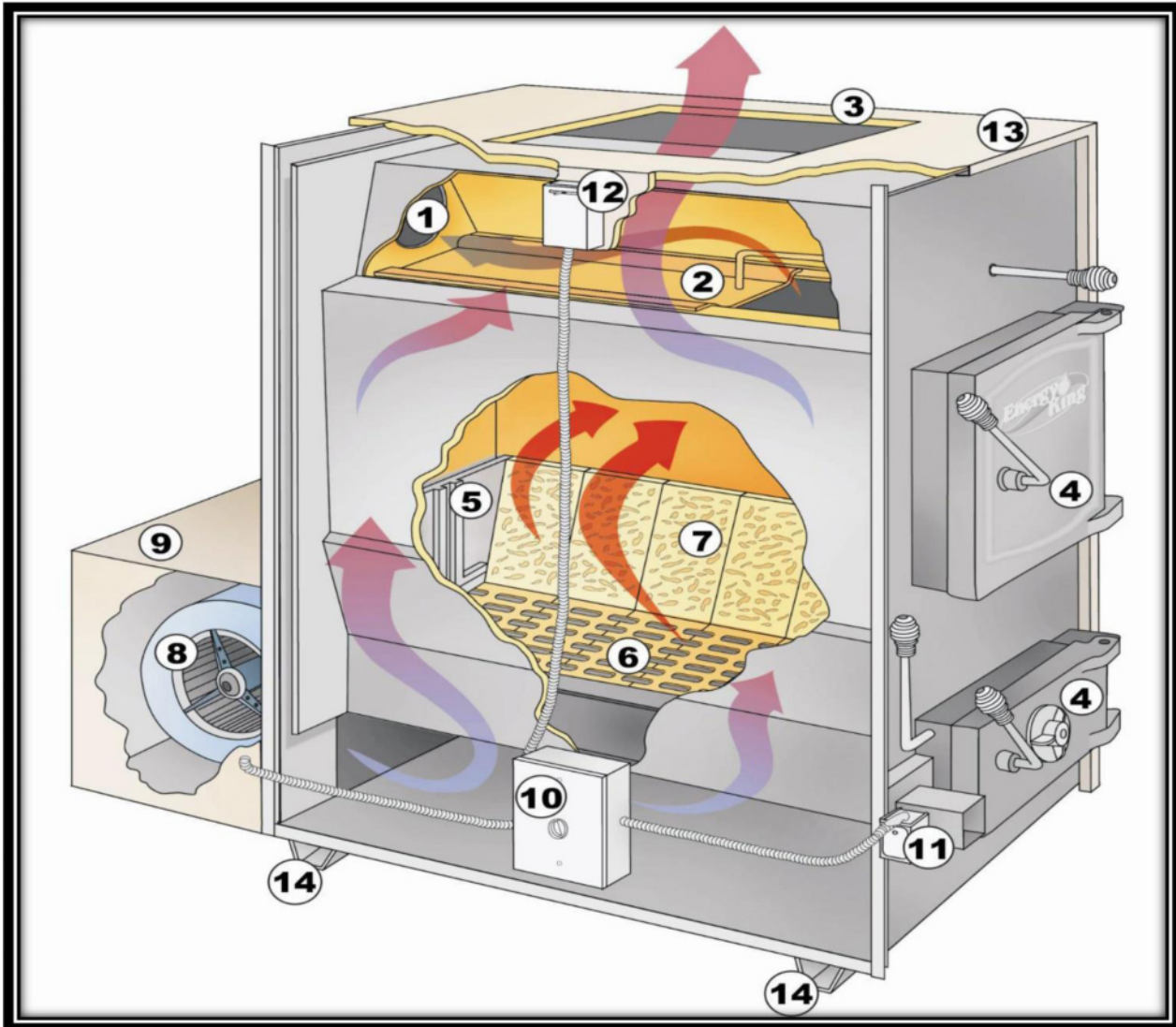

1. 6" Chimney Outlet. Venting must be provided using a lined masonry chimney or a listed UL103 type HT chimney. The chimney exhausts smoke and flue gases that are a natural result of combustion and provides "draft" to the Furnace. Draft is the force that moves air from the burn chamber up through the chimney. See *Venting* for further instructions.

2. Sliding Smoke Baffle. When open, the sliding smoke baffle allows smoke and flue gases to flow into the chimney connector without restriction. When closed, smoke and

flue gases are diverted around the sliding smoke baffle, creating a longer path for the heated air and allowing your furnace to extract the maximum amount of heat from the fire.

3. Plenum Opening. Allows you to connect the Furnace into your home's warm-air supply duct. ENERGY KING EK365/EK385 Furnace has a plenum opening of 18 inches by 18 inches. ENERGY KING EK480 Furnace has a plenum opening of 20 inches by 20 inches.

Component Description

4. Cast Iron Doors. Heavy cast iron fuel loading and ash removal doors are secured to the Furnace using door pins (4 included). The door gaskets provide an airtight seal and should be inspected regularly to ensure that they are in good condition at all times. The gasket must be replaced if it becomes damaged or worn. Do not operate the Furnace with the fuel loading or ash removal doors open.

5. Cast Iron Hearth Plates. Cast with the words "Wood" and "Coal" on opposite sides, these plates help to ensure the precise amount of combustion air required to promote the most efficient combustion for either fuel. ENERGY KING Wood/Coal Furnaces use two cast iron hearth plates—one at the front of the burn chamber, and one at the rear. (2 included).

Cast Iron Stationary (Wood) Grates. (Not pictured). This is where you build your wood fire. If you selected the Shaker Grate option, the Wood Grates will have been replaced with Shaker Grates at the factory.

6. Cast Iron Shaker Grates (Optional). This is where you build your wood or coal fire. The handle to control the Shaker Grates is located at the front of the Furnace, on the left side of the ash removal door.

7. Firebrick. (9" x 4-1/2" x 1-1/4") 2000-degree, heat retentive firebrick protects the sides of the Furnace's burn chamber. ENERGY KING EK365/EK385 Furnace uses 10 firebricks (5 on each side), while ENERGY KING EK480 Furnace uses 12 firebricks (6 on each side).

Ash Removal Pan. (Not pictured) Designed for easy cleanup of fine ash accumulation. Do not operate the Furnace with the ash removal door open; keep it closed except to remove ashes. The ash removal door gasket provides an airtight seal and should be inspected to ensure that it is in good condition at all times. The gasket must be replaced if it becomes damaged or worn.

8. Circulation Blower. The three-speed circulation blower, operated by the fan/limit control, forces air on all sides of the burn chamber, then into the home's duct system. The blower can be manually adjusted to run faster or slower to correspond to the amount of heat being produced.

9. Filter Box (optional). Provides air filtration for your cold-air return system. A non-combustible filter is required when using the optional filter box.

10. Control Box. Controls the Furnace's electrical system. The control box is pre-wired for your preferred draft system.

Combustion Fan. (Not pictured) If you selected Forced Air Draft, this fan will supply air for combustion by forcing air into the burn chamber when your wall thermostat calls for heat.

11. 24-V Damper Control Motor. If you selected Automatic Draft, this motor will supply combustion air to the burn chamber by automatically opening the draft damper door when your wall thermostat calls for heat.

Draft Dial. (Not pictured) If you selected Manual Draft, this spin dial will allow you to regulate the amount of combustion air being pulled into the burn chamber.

24-V Wall Thermostat. (Not pictured) Tells your Furnace when your home has cooled below your preferred temperature. Your automatic or forced air draft system is controlled primarily by your wall thermostat.

12. Fan/Limit Control. This control automatically starts and stops the circulation blower. It also features a limit switch which will cut power to the damper control motor or combustion fan if the temperature exceeds the set limit, while the circulation blower continues to run to cool the furnace.

13. Insulated Cabinet. The almond-colored steel cabinet panels (sides and top) restrain the foil-backed insulation, allowing maximum heat from the Furnace to be circulated through the home's warm-air supply duct system.

14. Legs. Raise the Furnace off the floor to prevent the accumulation of moisture between the floor and the bottom of the Furnace.

Domestic Hot Water Tube (Optional). (Not pictured) For heating domestic water.



Preinstallation Consideration

This Furnace is intended for use in residential buildings. Do not install this heating appliance in a mobile or manufactured home—*this can be dangerous and will void your warranty*. This heating appliance has not been tested to meet the strict requirements necessary for installation into a mobile or manufactured home.

Always check with local authorities and obtain the necessary permits prior to installing this heating appliance. This heating appliance must be installed in accordance with local, state and national codes and regulations.

Before the position of the Furnace can be decided, a few questions should be considered.

<p>1. Will this Furnace be used as a primary (central) furnace, or will it be installed as an add-on to your existing central heating system?</p> <p>2. Can the Furnace be vented properly?</p> <p>a. Is your chimney appropriate for this application? This Furnace requires installation into a UL103 Type HT all-fuel chimney. Do not connect this unit to a chimney flue serving any other appliance.</p> <p>b. Has your chimney been inspected? For your safety, it is important your chimney be clean and free from defect or damage prior to installing your Furnace.</p> <p>3. This Furnace may require an outside air source for combustion air. Will this be easily accessed in your desired location?</p> <p>4. Are there any local, state or national codes or regulations governing the use and placement of the Furnace?</p>	<p>5. Can the Furnace be installed safely?</p> <p>a. The Furnace should not be installed in a location where it could come into contact with curtains, drapes, walls, carpeting, or other combustible surfaces, and must not be installed in a sleeping room.</p> <p>b. Will your desired location require floor protection?</p> <p>c. The clearances specified in this manual are minimum clearances. Any reduction must be approved by the regulatory authority and is not recommended by Energy King</p> <p>6. How close is the electrical source? The power source must conform to the requirements shown in <i>Specifications</i>.</p> <p>7. Will the Furnace be easily accessible for cleaning, refueling, maintenance, and repair?</p> <p>8. Are there any structural reasons why the Furnace cannot be placed where you want?</p>
---	---

Finally, do you have a reliable, consistent source of fuel for your Furnace? Please see *Fuel Requirements* for further information on fuel supply.

Fuel Requirements

BURN AIR-DRIED WOOD, OR ANTHRACITE OR BITUMINOUS COAL ONLY



Risk of Fire: Do not store fuel or other combustible material within the marked installation clearances

It is important to use fuel that is clean, dry and consistent. Solid-fuel Furnaces, such as your ENERGY KING Wood/Coal Furnace, naturally produce ash as a byproduct of the burning process. Even with the ENERGY KING Furnace's efficient design, your Furnace will still produce some amount of ash which will need to be cleaned periodically. The type and quality of fuel you burn affects the amount of ash produced and the performance of your Furnace. To assist you in determining which fuel to use, here are some guidelines to consider:

WOOD

Burning wood for heat is as old as civilization itself. More than any other major fuel, wood provides us with energy independence – an easily available, locally produced and renewable source of heat on which we can rely.

- This Furnace has been tested for operation with air-dried wood.
 - Wood should be seasoned (dried) for at least 12 months before burning. Properly seasoned wood should have about 20% - 30% moisture content. To properly season wood, split the logs as soon as possible and loosely stack them in a dry spot for at least 12 months.
- You should not burn wet or green wood in your Furnace. Burning wet or green wood in your Furnace will not only reduce the efficiency of your appliance, but also increases the risk of dangerous creosote build-up in your appliance and chimney.
- Softwoods, such as pine and fir, are easily ignited and burn rapidly with hot flames. With softwoods, you will spend more time reloading your Furnace, and will have much more difficulty achieving an overnight burn. For a longer lasting fire, it is best to use more dense hardwoods.
 - Ideally, you should burn a mixture of hardwoods and softwoods, using the hotter, faster burning softwoods to start your fire, and the denser hardwoods to maintain a longer-lasting fire.
- With this in mind, choosing the kind of firewood that is best for you depends on what is available in your area. If hardwoods are unavailable in your area, you can control the burn rate by using larger pieces of wood and by adjusting your draft controls.
 - **DO NOT BURN:** Treated wood, colored paper, garbage, cardboard, solvents, or trash—burning these may result in toxic fumes, or produce soot and large flakes of char or fly ash. *Burning treated wood, colored paper, garbage, cardboard, solvents or trash can be dangerous and will void your ENERGY KING warranty.*
 - **DANGER – Risk of Fire or Explosion:** Do not burn garbage, gasoline, naphtha, drain or engine oil, or other flammable liquids or inappropriate materials in this Furnace.
- Storage**
- Store all fuel in a dry location away from the elements. Never burn wet or green wood.
 - Do not store fuel within the Furnace installation clearances or within the space required for refueling, ash removal and other routine maintenance operations.

Fuel Requirements

BURN AIR-DRIED WOOD, OR ANTHRACITE OR BITUMINOUS COAL ONLY



Risk of Fire: Do not store fuel or other combustible material within the marked installation clearances

COAL

One of the world's most widely-used fuel sources, coal can provide the energy independence and low fuel prices sought by owners of solid-fuel heating appliances.

- This Furnace has been tested for operation with anthracite (hard) or bituminous (soft) coal.
- **Anthracite:** Also known as Hard Coal, anthracite is a hard, lustrous coal with a high carbon content that burns with a clean blue, nearly smokeless, flame.
- **Bituminous:** Also known as Soft Coal, bituminous coal is a soft type of coal that has a high sulfur content and burns with a yellow, smoky flame.
- Bituminous coal tends to contain more impurities and sulfur than anthracite coal, which may decrease the expected lifespan your ENERGY KING solid-fuel heating appliance and its components. Only burn high-grade bituminous coal.
- **Coal Size:** Your ENERGY KING Wood/Coal Furnace is designed to use coal that is Nut size or larger.
- **DO NOT BURN:** Treated wood, colored paper, garbage, cardboard, solvents, or trash—burning these may result in toxic fumes, or produce soot and large flakes of char or fly ash. *Burning treated wood, colored paper, garbage, cardboard, solvents or trash can be dangerous and will void your ENERGY KING warranty.*
- **DANGER – Risk of Fire or Explosion:** Do not burn garbage, gasoline, naphtha, drain or engine oil, or other flammable liquids or inappropriate materials in this Furnace.

Storage

- Store all fuel in a dry location away from the elements. Never burn wet coal.
- Do not store fuel within the Furnace installation clearances or within the space required for refueling, ash removal and other routine maintenance operations.

Installation



Risk of Fire:

- Do not operate with flue draft exceeding .06 in. (14.95 Pa) water column.
- Do not operate with fuel loading or ash removal doors open.
- Do not store fuel or other combustible material within marked installation clearances
- Inspect and clean flues and chimney regularly.



Do not connect the ENERGY KING heating appliance to any chimney flue serving any other appliance.

General Requirements

The installation of any solid-fuel heating appliance is not a do-it-yourself project. The ENERGY KING Wood/Coal Furnace should be installed by a qualified installer with specific knowledge of central heating systems. Check with your fire department and building inspector for local, state, and national codes and regulations regarding installation.

Solid-fuel heating appliance related fires are caused almost exclusively by installation, operation, or maintenance errors. A smoke detector in “working” condition **must** be a part of every ENERGY KING solid-fuel heating appliance installation—this is the most inexpensive insurance you can buy! For additional safety, Energy King recommends installing working smoke detectors and a listed carbon monoxide warning device in the living areas of the home.

The ENERGY KING Wood/Coal Furnace is designed to be used in conjunction with a listed gas- or oil-fired furnace, or as a central Furnace.

Placement

• Floor Protection

Floor protection must be provided because of possible spillage of ashes and burning fuel. The ENERGY KING Wood/Coal Furnace must be installed on a non-combustible floor or 3/8-inch thick fireproof millboard or equivalent.

The non-combustible material must be placed underneath the furnace, and must extend at least 18 inches on all sides of the Furnace, and at least 8 inches on either side of the fuel loading and ash removal doors.

Additionally, the non-combustible material must extend at least 18 inches on either side of the chimney connector.

Consult your local ENERGY KING dealer for possible sources of non-combustible floor protection material acceptable for use with your ENERGY KING Wood/Coal Furnace.

• As Primary Furnace

Locate the ENERGY KING Wood/Coal Furnace as close to the new or existing chimney as possible and as central to the heat distribution system as practical.

Additionally, the ENERGY KING Wood/Coal Furnace should be placed so that you can easily complete operation and maintenance procedures.

Strictly adhere to all requirements pertaining to clearances to combustibles, combustion air, venting system, draft control, and thermostat installation.

Installation

• As Add-On Furnace:

The ENERGY KING Wood/Coal Furnace is designed to be used in conjunction with a listed gas- or oil-fired furnace, but not all furnaces will accept an add-on application. Some small furnaces, and especially counter-flow or down-flow furnaces, may not be used in an add-on installation.

The CFM (cubic feet per minute) capability between the blower on the existing furnace and the add-on furnace must be compatible. If all of these conditions are met, then the combined static pressure may not exceed that established by the existing furnace.

Before installing your ENERGY KING Wood/Coal Furnace, consult your ENERGY KING dealer or heating contractor and your local, state and national building codes and regulations to determine if your existing central heating system is compatible with your ENERGY KING Wood/Coal Furnace.

Once it has been determined that your existing furnace will accept an add-on installation, Energy King recommends a parallel installation, with a direct (ducted) feed of return air to the ENERGY KING Wood/Coal Furnace.

Install two backflow dampers to ensure that when either furnace is operating independently, hot air will not flow back through the other furnace.

When using your ENERGY KING Wood/Coal Furnace as an add-on, locate the ENERGY KING as close to the new or existing chimney as possible and as close to your existing furnace as practical. However, a minimum clearance of 6-inches is required between your existing furnace and your ENERGY KING Wood/Coal Furnace.

Clearances to Combustibles:

- **Sides:** The ENERGY KING must have clearances of 18 inches from the sidewall of the ENERGY KING wood/coal Furnace to combustibles.
- **Front:** Leave a minimum clearance of 48 inches in front of your ENERGY KING wood/coal Furnace. This is for safe, easy loading and cleaning of your ENERGY KING.
- **Rear:** The minimum clearance from the rear of the ENERGY KING wood/coal Furnace to combustibles is 28 inches
- **Top:** The minimum clearance from the top of the ENERGY KING Wood/Coal Furnace to combustibles is 18 inches.
- **Stovepipe:** Stovepipe must have a minimum of 18 inches from the rear to combustibles, and a minimum of 20 inches from the sides to combustibles.
- Additionally, when using your ENERGY KING wood/coal Furnace as an add-on, a 6-inch minimum clearance is required between the ENERGY KING Furnace and your existing furnace.

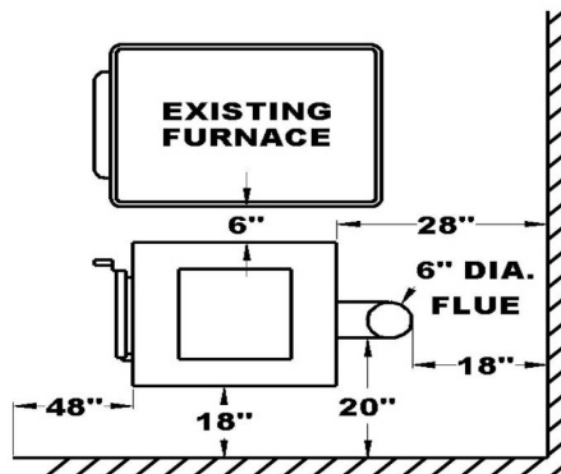



Installation

Assembling Your ENERGY KING Wood/Coal Furnace

The entire installation should be planned before putting the furnace in place to ensure compliance with all the requirements outlined in the owner's manual and any applicable markings on the appliance.

Your new ENERGY KING Wood/Coal Furnace will have been shipped on a pallet with several boxed components that will need to be assembled prior to installation. Please see *Components* for a list of everything that was shipped along with your ENERGY KING Wood/Coal Furnace.

Once your furnace is placed in your desired location:

1. Remove the protective plastic coating from the outer cabinet of the Furnace before assembling.
2. **Cast Iron Hearth Plates.** Position front and rear cast iron hearth plates in the burn chamber. Your primary type of fuel (wood or coal) will determine how to position the hearth plates. The words "Wood" and "Coal" are cast into the end plate on opposite sides. The purpose of proper location is to introduce the precise amount of combustion air into the burn chamber to promote the most efficient combustion for either fuel.
 - a. If you are going to burn wood, position the hearth plates with the word "Wood" facing out, not into the burn chamber.
 - b. If you plan to primarily burn coal, position the hearth plates with the word "Coal" facing out.
3. **Firebrick.** The firebrick in your ENERGY KING Furnace will have been installed at the factory; however, they may have shifted during shipment. If adjustments are needed, position the firebrick by standing up on end on the left and right sides of the burn chamber.

The ENERGY KING EK365/EK385 Wood/Coal Furnace uses 10 firebricks (5 on each side), while the ENERGY KING EK480 Wood/Coal Furnace uses 12 firebricks (6 on each side).
4. **Cast Iron Doors.** Mount the fuel loading door and ash removal door on the front of the Furnace and secure with the enclosed door pins.

Installation

5. Control Box.

- a. Remove the control box cover. See *Figure 3: Control Box for Automatic Draft*, *Figure 4: Control Box for Forced Air Draft*, or *Figure 5: Control Box for Manual Draft*.
- b. Mount the pre-wired control box on the lower left side of the Furnace using the screws provided.

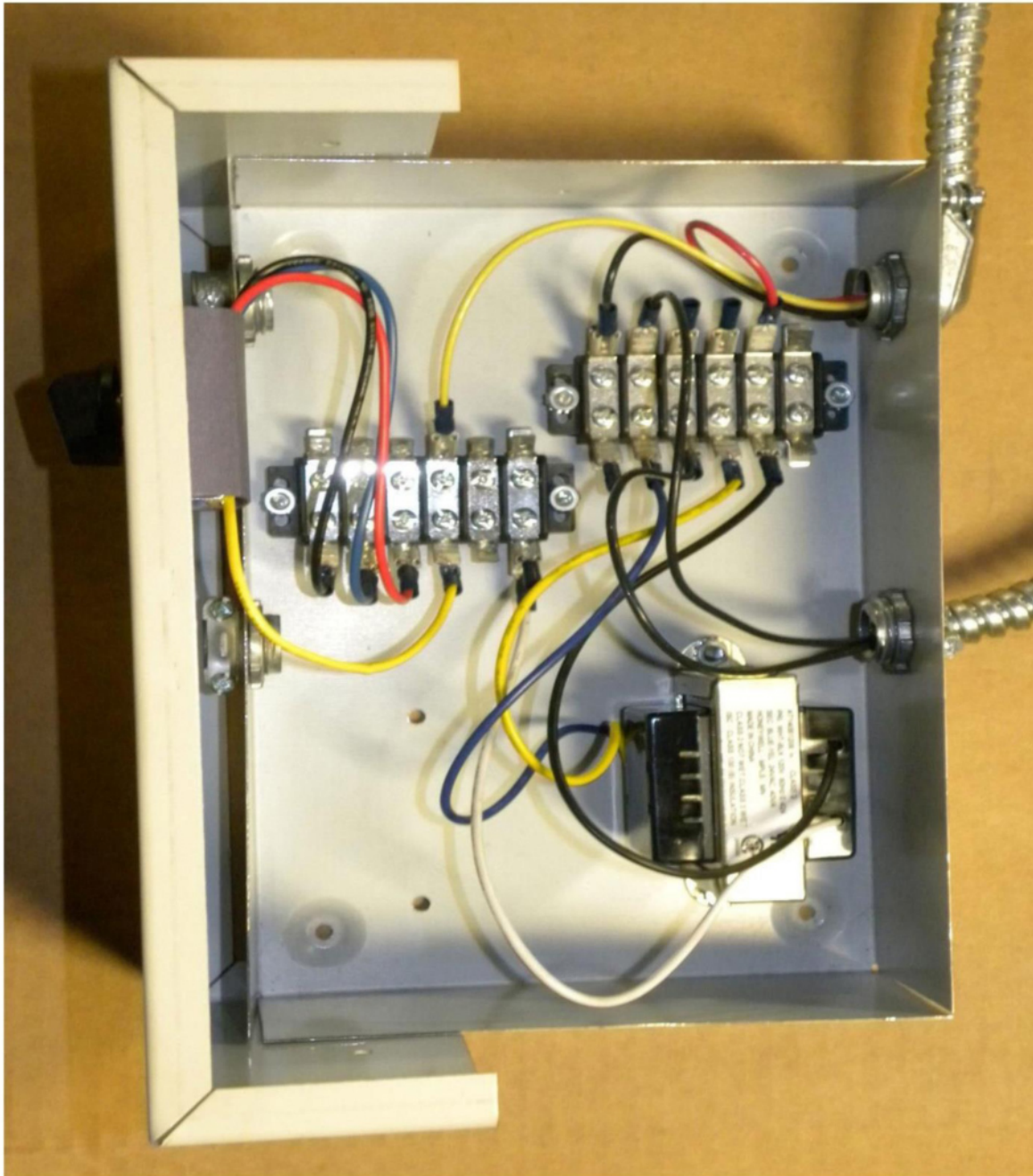

Control Box for Automatic Draft

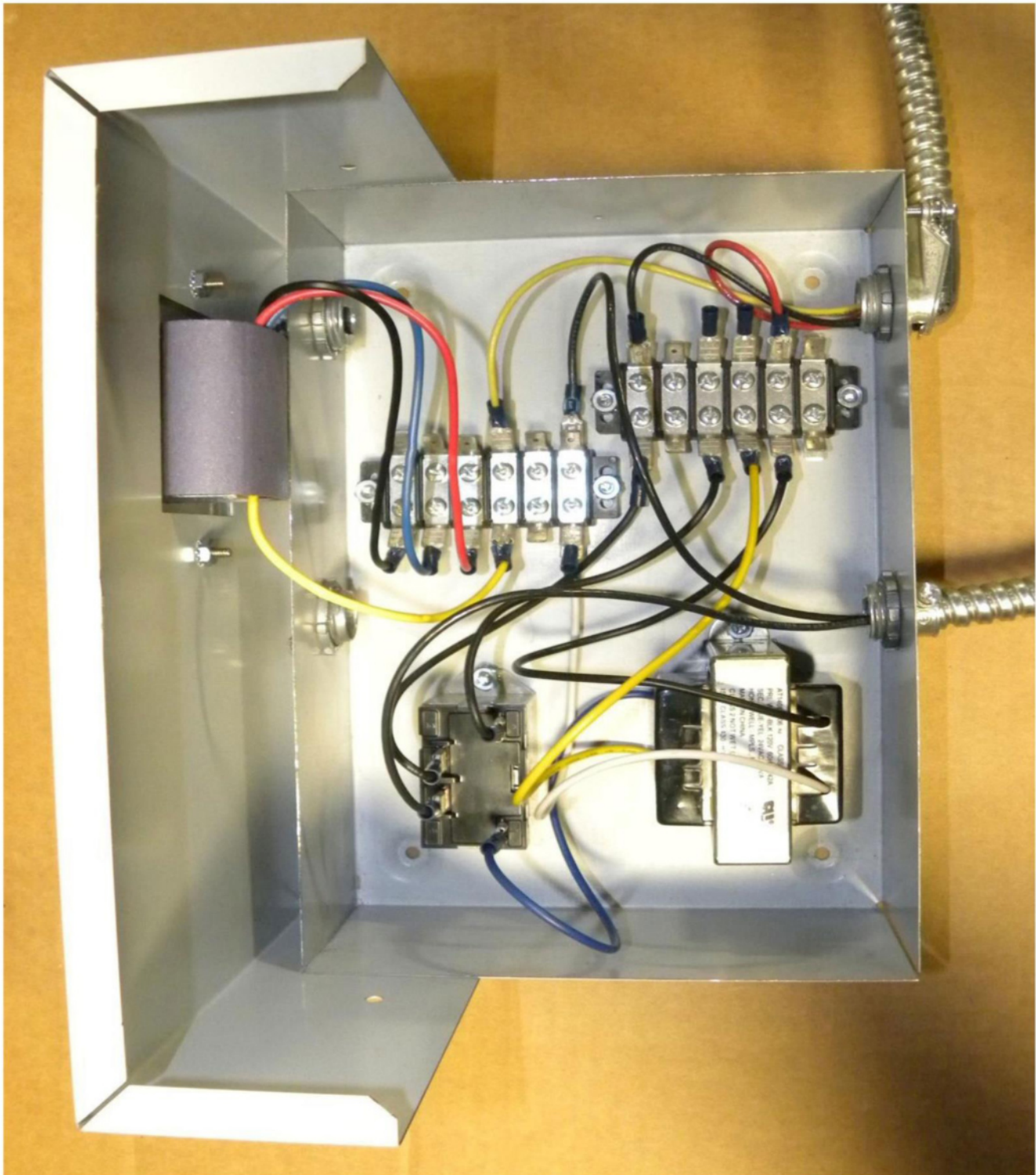

Control Box for Forced Air Draft

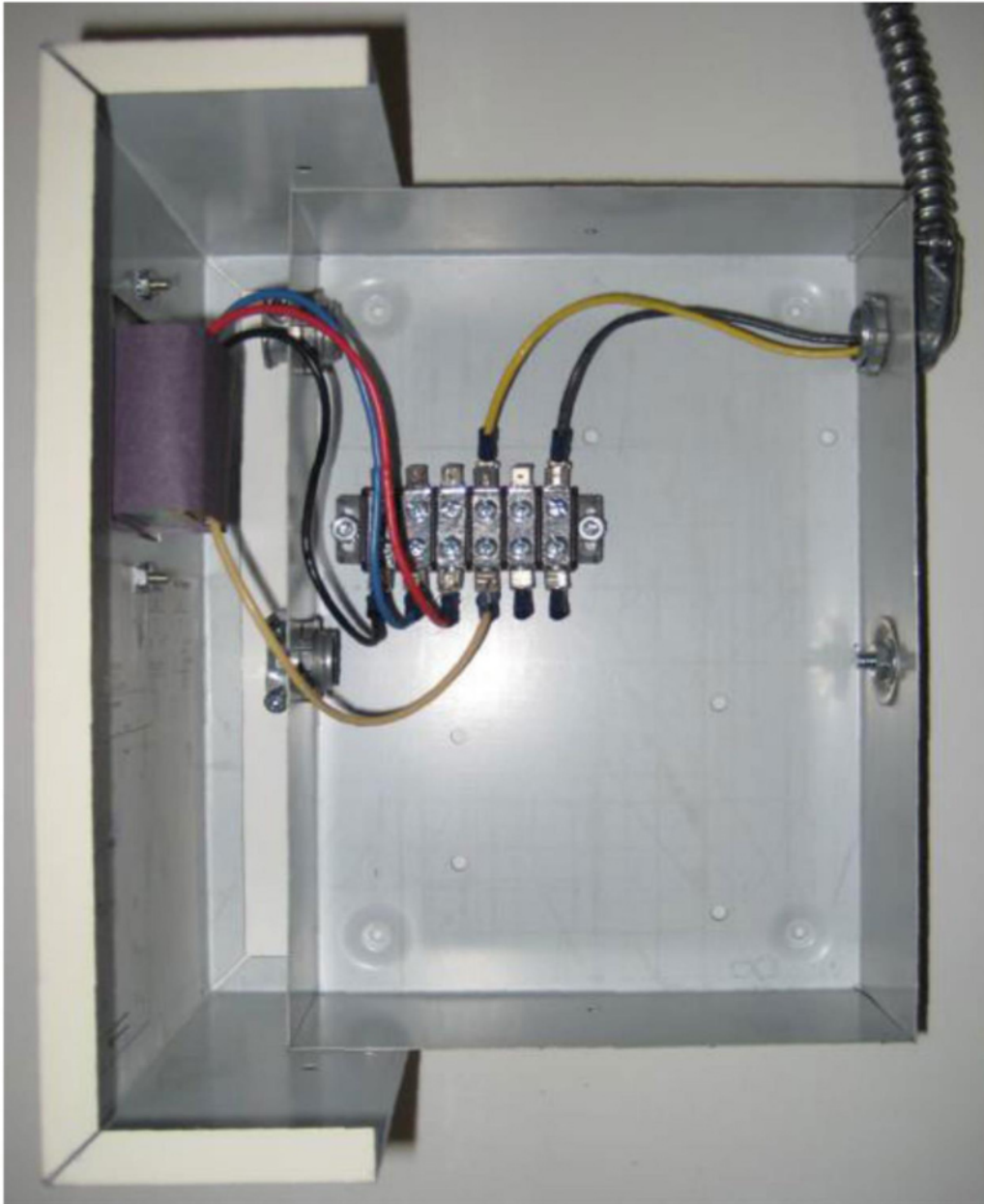

Control Box for Manual Draft

Installation

6. **Draft System.**

- a. Insert the conduit leading from your chosen draft system into the control box and tighten screw to secure.
- b. *For Automatic Draft.* Mount the automatic draft tube with the pre-wired damper control motor to the draft opening located next to the ash removal door on the lower left front of the Furnace, and secure using the bolts found on the draft opening.

Automatic Draft Tube with Damper Control Motor

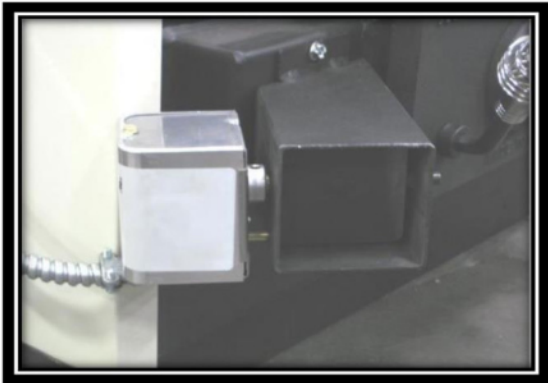

- c. *For Forced Air Draft.* Mount the prewired forced air draft blower to the draft opening located next to the ash removal door on the lower left front of the Furnace, and secure using the bolts found on the draft opening.

Forced Air Draft Blower

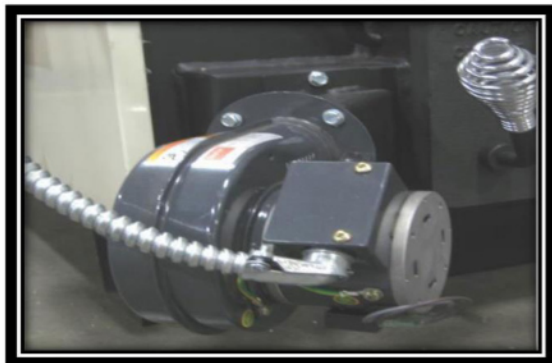

- d. *For Manual Draft.* Mount the manual draft tube with attached spin dial to the draft opening located next to the ash removal door on the lower left front of the Furnace and secure using the bolts found on the draft opening.

Manual Draft Tube with Spin Dial



7. **Fan/Limit Control.**

- a. Remove the cover of the fan/limit control.
- b. Mount the fan/limit control to the side of the furnace directly above the control box. Attach into the pre-punched holes using the screws provided.

Fan/Limit Control, Mounted



Installation

- c. **Set Pointers.** Hold dial securely with one hand and move the pointers with the other hand. Do not force the pointers past any stops on the dial even though the dial may be graduated beyond the stops.
 - i. **Limit.** Verify that the right hand pointer is set at 200-degrees F. This is the temperature at which contacts should open to prevent your Furnace from overheating. Never set the Limit pointer higher than 200-degrees F, as recommended by the Fan/Limit Control manufacturer.
 - ii. **Fan.** Move the "Fan On" pointer so that its straight edge indicates the temperature at which the fan contacts should close to start the blower. Move the "Fan Off" pointer so that its straight edge indicates the temperature at which the fan contacts should open to stop the blower. Recommended "Fan On" setting is 145-degrees F. Recommended "Fan Off" setting is 90-degrees F.



Fan/Limit Control Settings

Recommended "Fan Off" setting is 90°F.
Recommended "Fan On" setting is 145°F.

- 8. **Circulation Blower.**
 - a. Mount circulation blower on rear of furnace using the four bolts supplied.
 - b. If you selected the optional Filter Box kit, proceed to step 9. Otherwise, attach the conduit to Control Box and connect wire ends as detailed in *Appendix A: Wiring Diagrams*. **Do not connect power to your ENERGY KING Wood/Coal Furnace until the installation is complete.**

9. Cold Air Return & Optional Filter Box.

- a. Determine whether your cold air return will enter on the left or right side of the furnace.
- b. Assemble the optional filter box per *Appendix B: Filter Box Assembly Schematic*.
- c. Feed the conduit from your circulation blower through the hole located on the top of the filter box. Attach the conduit to Control box and connect wire ends as detailed in *Appendix A: Wiring Diagrams*. **Do not connect power to your ENERGY KING Wood/Coal Furnace until the installation is complete.**

10. Domestic Hot Water Tube (Optional).

- a. Your optional domestic hot water tube may have been installed at the factory. If so, your plumber can connect your domestic hot water supply per the installation instructions provided by the hot water tube manufacturer.
- b. If your optional domestic hot water tube was not factory-installed, please follow the installation instructions provided by the hot water tube manufacturer.

- 11. **Wiring.** *Do not connect power to your ENERGY KING Wood/Coal Furnace until the installation is complete.*

Once you've completed the installation of your ENERGY KING Wood/Coal Furnace, you may connect your 110V power supply to the left side of the control box. Wiring is based on draft choice. Please see *Appendix A: Wiring Diagrams*.



Risk of electric shock.

Disconnect power at the service panel or breaker box before servicing the ENERGY KING Wood/Coal Furnace

Installation

Combustion Air Requirements



Failure to provide adequate combustion air can lead to increased carbon monoxide production and increased emissions of combustion gases into the building, which may cause death or serious injury.

The ENERGY KING Furnace must have a minimum supply of 70 cubic feet of air per minute.

All fuel-burning appliances must have air (oxygen) for proper combustion. The incomplete combustion that takes place when a solid-fuel appliance is “air-starved” causes carbon monoxide (CO) production in quantities that can be dangerous inside a building. Combustion air from outside may need to be brought in to prevent “air starvation”. Although an outside air source is strongly recommended for all installations, it may be necessary if:

- The Furnace does not draw steadily, smells, experiences smoke roll-out, burns poorly, or back drafts whether or not there is combustion present.
- Any of the above symptoms are alleviated by opening a window slightly on a calm day.
- The house is equipped with a well-sealed vapor barrier and tight fitting windows and/or has any powered devices which exhaust house air, such as clothes dryers.
- A ventilation system is installed in the house.

Consult a qualified Furnace installer to analyze whether the air supply in your installation environment is adequate.

Installation

Venting System



- **Failure to provide correct chimney venting can lead to increased carbon monoxide production and increased emissions of combustion gases into the building, which may cause death or serious injury.**
- **Do not connect ENERGY KING heating appliance to any chimney flue servicing any other appliance.**
- **Risk of Fire: Inspect and clean flues and chimney regularly.**
- **Risk of Fire: Do not operate with the flue draft exceeding .06" (14.95 Pa) water column.**

Consult a qualified Furnace installer, your local building inspector and your fire officials to make sure the chimney and all connections conform to all local, state and national codes and regulations.

<p>Your venting system is an extremely important part of any solid-fuel heating appliance installation and has two key functions:</p> <ol style="list-style-type: none"> 1. To exhaust smoke and flue gases which are the natural result of combustion. 2. To provide "draft." The draft pulls a continuous supply of fresh air into the furnace for proper combustion. <p>A chimney connector and chimney make up the venting system and must be properly installed and maintained to protect against a fire. Consult a venting professional.</p> <p>The ENERGY KING Wood/Coal Furnace requires installation into a listed UL103 type HT all-fuel chimney. Minimum 24 gauge black steel chimney connector is required. An existing chimney must be cleaned and inspected to be sure it is clean and free from defect or damage. All connections must comply with NFPA Standard 211 and all applicable building codes and regulations.</p> <p>When installing a factory-built chimney, follow all installation instructions provided by the chimney manufacturer.</p> <p>For best performance, Energy King recommends using insulated chimney rather than triple wall or air cooled chimney.</p>	<p>Important venting installation clearances and points for proper operation and safety:</p> <ul style="list-style-type: none"> • The connection from the ENERGY KING Wood/Coal Furnace to the chimney must be made using 6" black steel material with a minimum 24 gauge. Do not use galvanized steel. See <i>Chimney Connector</i>. • Secure all connector pipe joints with at least three sheet metal screws. • Any horizontal runs of chimney connector pipe should have a minimum rise of 1/2-inch per linear foot. • A minimum distance of 18 inches must be maintained between the chimney connector and combustible ceiling surfaces. A minimum of 18 inches must be maintained between the chimney connector and the backwall and a minimum of 20 inches must be maintained between the chimney connector and sidewalls. • Avoid using more than two elbows in connecting the ENERGY KING Wood/Coal Furnace to the chimney. • Use extra support hangers or brackets every three feet if it is absolutely necessary to have a run of more than six feet, which is not recommended. • The Chimney must be at least 3 feet higher than the highest point where it passes through the roof, and at least 2 feet higher than the highest part of the roof or structure that is within 10 feet of the chimney, measured horizontally. For best performance, Energy King recommends a chimney height of at least 12 feet.
--	--

Installation

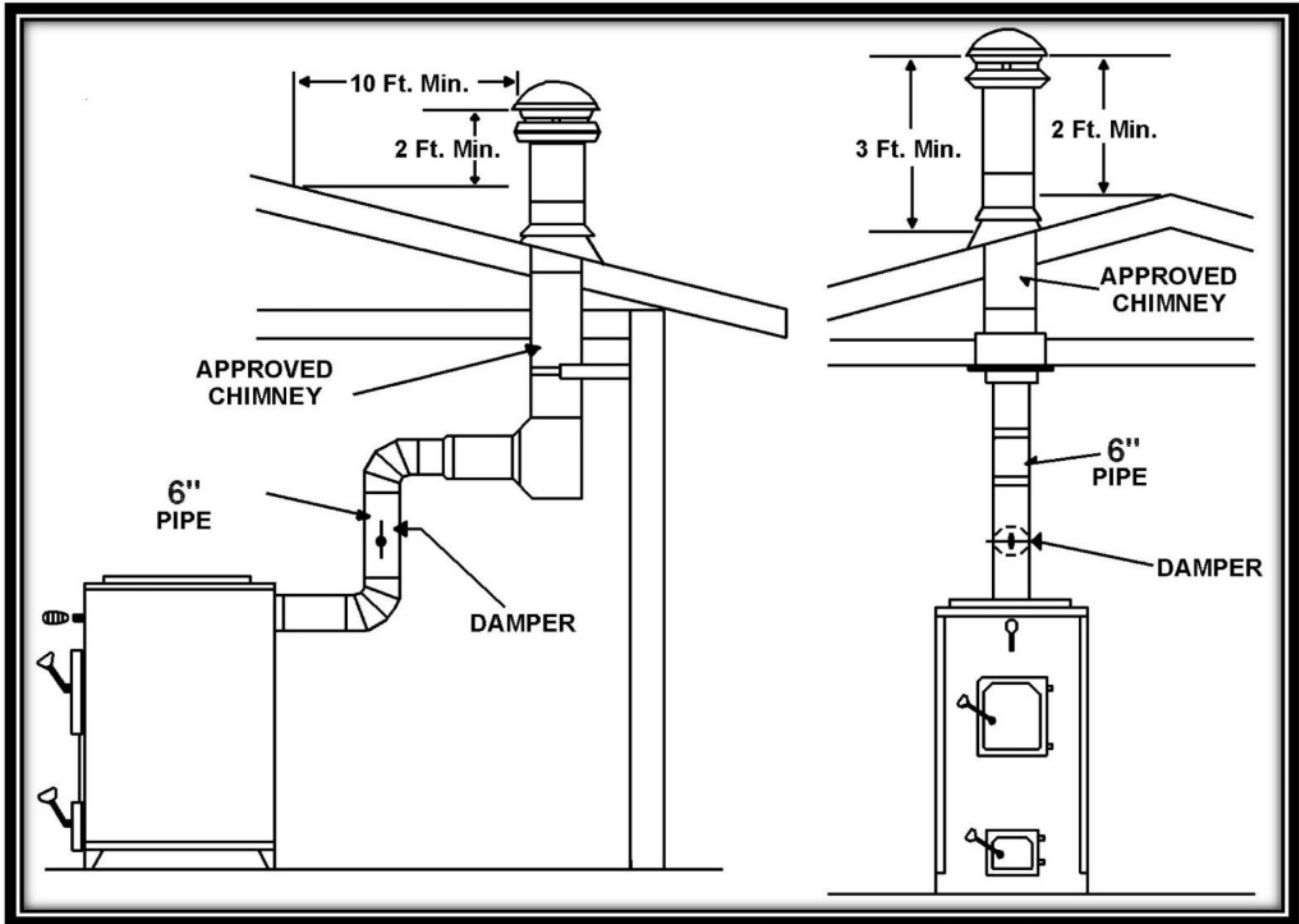

Venting Requirements

The Chimney must be at least 3 feet higher than the highest point where it passes through the roof, and at least 2 feet higher than the highest part of the roof or structure that is within 10 feet of the chimney, measured horizontally. For best performance, Energy King recommends a chimney height of at least 12 feet.

Installation

Masonry Chimney

When connecting to an existing masonry chimney, an approved liner must be used in the chimney. **An unlined chimney could remain cold and cause a downward pressure which creates the environment for poor burning, incomplete combustion, or backdraft.**

Chimney Connector

The connection from the ENERGY KING Wood/Coal Furnace to the chimney must be made using 6" black steel material with a minimum 24 gauge. Do not use galvanized steel.

For proper operation, the chimney connector should be as short as possible. Horizontal lengths of chimney connector should have an upward slope of 1/2-inch per foot. Use extra support hangers or brackets every three feet if it is absolutely necessary to have a run of more than six feet, which is not recommended.

Chimney connector sections must be attached to the heating appliance and to each other with the crimped end toward the heating appliance. Secure all chimney connector pipe joints with at least three sheet metal screws. Avoid using more than two elbows in connecting the ENERGY KING Wood/Coal Furnace to the chimney.

Never use chimney connector pipe as a chimney.

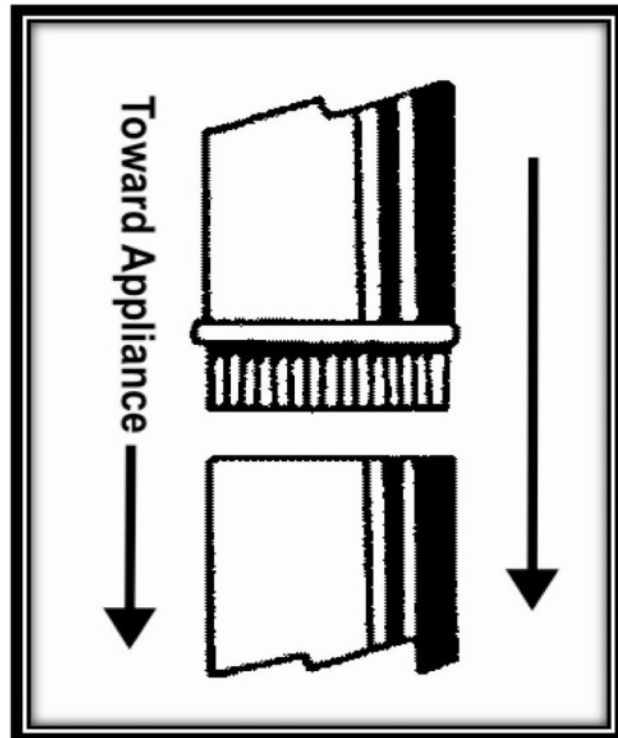

Chimney Connector Section

A minimum distance of 18 inches must be maintained between the chimney connector and combustible ceiling surfaces.

A minimum of 18 inches must be maintained between the chimney connector and the backwall and a minimum of 20 inches must be maintained between the chimney connector and sidewalls.

DO NOT PASS CHIMNEY CONNECTOR THROUGH A COMBUSTIBLE WALL OR CEILING.

Installation

Barometric Draft Control



Risk of Fire: Do not operate with the flue draft exceeding .06" (14.95 Pa) water column.

Proper draft must be provided for your ENERGY KING Wood/Coal Furnace. Draft is the force that moves air from the furnace up through the chimney, and is measured in inches of water column.

The amount of draft in your chimney depends on the length of the chimney, local geography, nearby obstructions and other factors. Too much draft may cause the fire to burn too fast, while inadequate draft may cause smoke to back up into the ENERGY KING Wood/Coal Furnace, creating a possible hazard. A barometric draft regulator must be installed into the chimney connector. Please see *Figure 13: Barometric Draft Control*.

Draft regulators limit the draft (the suction pulling air into the solid-fuel heating appliance burn chamber). A pivoted, counterbalanced flap is pulled open by the draft when the draft

reaches a critical amount. This permits air to enter the chimney, thus preventing the draft in the solid-fuel heating appliance from rising any higher.

Install the barometric draft control as close to the Furnace as possible. On extremely tall chimneys or chimneys larger than 6", it may be necessary to install a second barometric draft control, or reduce the outlet opening of the chimney to approximately 28 square inches, or both, to maintain the chimney draft to .04" to .06" water column of draft.

After installation of the ENERGY KING Wood/Coal Furnace is complete and a fire has been built, the chimney draft should be established and maintained from .04" to .06" water column of draft. If this setting is exceeded, it could cause a solid fuel fire to burn out of control.

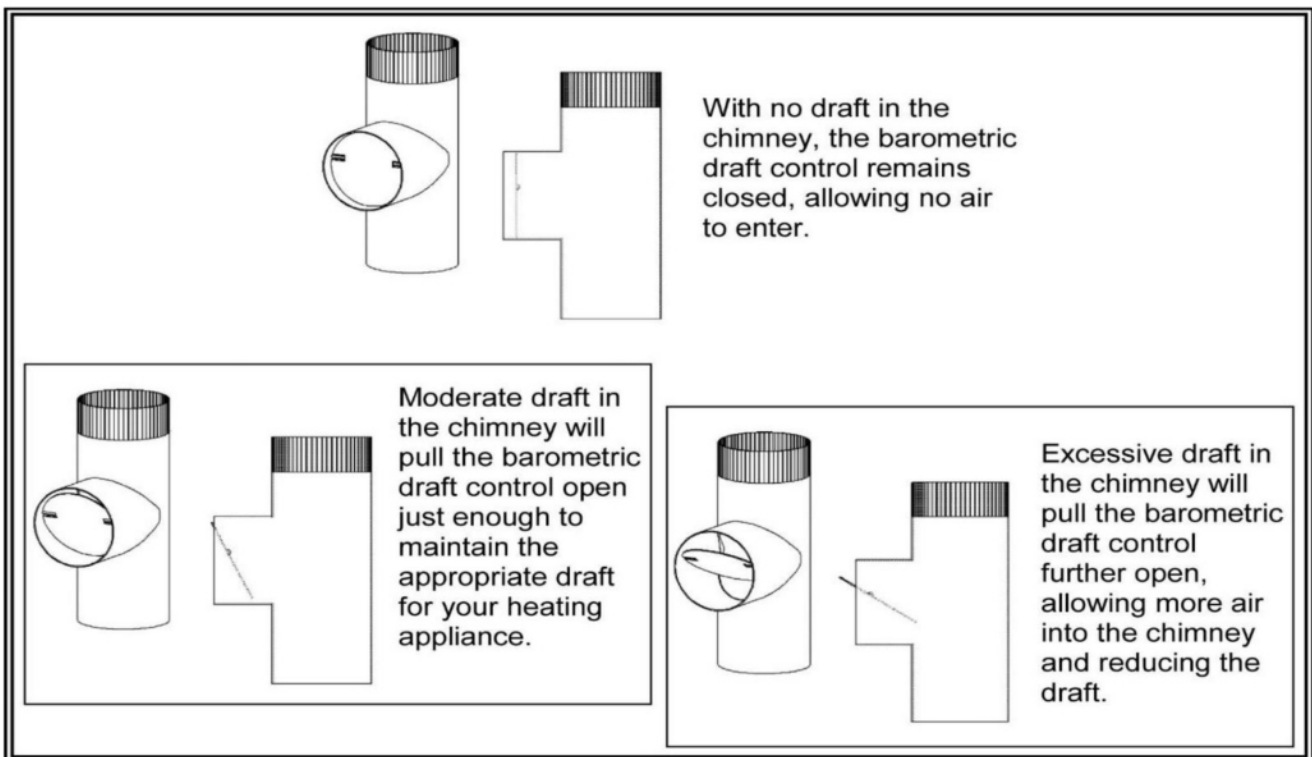

Installation

Air Duct Installation



Do not connect the ENERGY KING warm air supply outlet into the cold air return inlet of the central furnace. The components of the central furnace could overheat causing the central furnace to operate other than intended.

The duct or air distribution system circulates heated and/or cooled air to all the conditioned rooms in a house. They must be properly designed and installed to be efficient, maintain uniform temperatures throughout the house, and not adversely affect comfort or indoor air quality.

Important duct system installation details for safe and efficient operation of your ENERGY KING Wood/Coal Furnace:

<ul style="list-style-type: none"> • Every ENERGY KING Wood/Coal Furnace must be installed with a cold air return. Cold air returns must be equal in size to the heated air outlets, and preferably 10% larger. • The plenum must be constructed of metal (minimum 28 gauge galvanized is recommended) and must be installed in accordance with NFPA guidelines. • The plenum should be: <ul style="list-style-type: none"> ○ 18 inches by 18 inches for the models EK365/EK385 ○ 20 inches by 20 inches for the model EK480 • The plenum must be no closer than 2 inches from the ceiling or any combustible material. This clearance is critical during a power outage since excessive heat buildup in the plenum top may be dangerous. 	<ul style="list-style-type: none"> • When connecting the plenum to your warm-air-supply duct system, never supply less than 150-square inches of constant heated air outlet area. • The warm-air-supply duct system must be constructed of materials with a minimum temperature rating of 250 degrees Fahrenheit. • The ducts, fittings and registers should be sized so that the total external static pressure does not exceed 0.2. • Ductwork clearance requirements vary. Contact your local building or fire officials about installation restrictions and inspection requirements in your area. Ductwork installation must conform to local, state, and national codes and regulations.
---	--

Operation

General Instructions



Risk of Fire:

- Do not operate with flue draft exceeding .06" (14.95 Pa) of water column.
- Do not operate with fuel loading or ash removal doors open.
- Do not store fuel or other combustible material within marked installation clearances.
- Inspect and clean flues and chimney regularly.



CAUTION – Hot Surfaces: Keep children away!
Do not touch Furnace during operation.

Please read this manual in its entirety prior to the first firing of your ENERGY KING Wood/Coal Furnace. It is very important that you follow these suggestions and limitations in order to maintain your warranty and to guarantee the long life of your ENERGY KING Wood/Coal Furnace.

This ENERGY KING Wood/Coal Furnace is designed to burn for about 6 to 8 hours per load of wood or coal. If the ENERGY KING Wood/Coal Furnace is being fired hot constantly with full flames and operating at only a 2 to 4 hour burn cycle, **it is being overfired**. Your home heating needs may be too great for the size of Furnace you have purchased.

Sometimes you need to allow your existing conventional heating system to assist you in colder weather. Your ENERGY KING Wood/Coal Furnace can be damaged if it is constantly fired at extremely high temperatures. Forced firing or abuse can be detected upon inspection **and will void your warranty**.

During the warmer seasons of spring and fall, you should control the heat output by limiting the amount of fuel, rather than the air supply. Shorter, hotter fires will allow your ENERGY KING heating appliance to operate at maximum efficiency and with minimum emissions.

For best combustion efficiency, chimney temperature should be 350-degrees F to 450-degrees F. Energy King recommends installing a magnetic chimney thermometer to monitor chimney temperature.

First Fire

Before lighting your first fire, inspect your ENERGY KING Wood/Coal Furnace to ensure that it has been properly installed and that all safety requirements have been met. During your inspection, pay particular attention to the clearances to combustibles, venting, and thermostat installation instructions.

Check to make sure that your blowers are in proper working order.

- To check the circulation blower, use the manual switch on the fan/limit control.
- If you selected Forced Air Draft, you can check the forced draft blower by turning the wall thermostat supplied with your ENERGY KING to a high temperature. If your draft blower turns on, you may set the wall thermostat to the desired setting.

Next, make sure that the burn chamber and ash removal pan are clear of all objects. Do not fully load your ENERGY KING Wood/Coal Furnace or open all draft controls completely until you become familiar with the operation of your ENERGY KING Wood/Coal Furnace.

Some odors may be given off a new ENERGY KING Wood/Coal Furnace during the initial few hours of burning while the steel and the paint are being cured. Ventilating the room until the odors disappear is recommended.

Operation

Typical Operation Cycle



Risk of Fire:

- Do not operate with flue draft exceeding .06" (14.95 Pa) water column.
- Do not operate with fuel loading or ash removal doors open.
- Do not store fuel or other combustible material within marked installation clearances
- Inspect and clean flues and chimney regularly.



CAUTION – Hot Surfaces: Keep children away!
Do not touch Furnace during operation.

After a fire has been established and the operating temperature has been reached, only the thermostat needs to be set to maintain the desired temperature.

When your home cools, the thermostat located in the living area of the home activates the draft control system.

- If you selected Automatic Draft, the automatic draft damper will open, allowing your chimney's natural draft to pull combustion air into the burn chamber.
- If you selected Forced Air Draft, the combustion fan turns on, forcing combustion air into your burn chamber.
- If you selected Manual Draft, there is not a thermostat that will regulate the amount of combustion air in your Furnace.
 - For a higher burn rate, turn the manual draft spin dial to the left.
 - For a lower burn rate, turn the manual draft spin dial to the right.
 - The manual draft spin dial can be set to any position between high and low to achieve the desired burn rate for your home.

The 3-speed circulation blower is activated when the temperature sensor of the fan/limit control indicates that air has been heated to the fan/limit control ON temperature setting. The circulation blower pushes air around the burn chamber, through the heat exchanger area and into the plenum.

When the thermostat is satisfied, it will deactivate your automatic or forced air draft control system, allowing the fire to die down until the next time your thermostat calls for heat.

Your ENERGY KING Wood/Coal Furnace can run efficiently over extended periods of time and at different heat output levels as long as the fuel supply is uninterrupted and cleaning and maintenance are performed routinely.

Power Failure Instructions



Always closely monitor the operation of the ENERGY KING Wood/Coal Furnace during a power failure.

To operate your ENERGY KING Wood/Coal Furnace in the event of a power failure:

1. Close draft dial on ash door.
2. Remove air filter.
3. Open all heat registers.
4. Do not load the Furnace more than 1/4 full.
5. Keep sliding smoke baffle closed.

Use extreme caution when operating your ENERGY KING Wood/Coal Furnace during a power failure. Over-firing can damage the furnace and its components, will void your warranty, and may result in property damage, bodily injury or even death.



Operation

BURN AIR-DRIED WOOD, OR ANTHRACITE OR BITUMINOUS COAL ONLY

Burning Wood

All home chimneys and hookups are different. After a few fires, you will find the best way to start a fire in your ENERGY KING Wood/Coal Furnace.

Your ENERGY KING Wood/Coal Furnace is capable of holding very large logs. **Do not** try to add a log that is larger than what you can easily place in the ENERGY KING Wood/Coal Furnace. You will get the best efficiency when you add only the amount of wood needed for a 6 to 8 hour burn. Note: A full load is not always the best solution for your needs.

Starting a Wood Fire

1. Pull the sliding smoke baffle (located above the fuel loading door) out to open.
2. Place a small amount of crumpled paper in the center of your ENERGY KING Wood/Coal Furnace. Crisscross a couple of handfuls of dry, 3/4" thick kindling wood, then several small pieces of firewood.

Be sure the sliding smoke baffle is fully open.

3. It will take 5 to 10 minutes for the fire to establish itself. Once you have some red-hot burning embers, add larger pieces of wood.
 - a. Vary the position of the wood in the burn chamber to maximize the exposed surface area of each piece of wood.
 - b. Only use wood properly sized for your unit's burn chamber.

Never overload your burn chamber. Do not load wood more than 8 inches above the top of the firebrick

4. Push in the sliding smoke baffle after loading your ENERGY KING and the fire has been established.

5. The burn time is controlled totally by the automatic or forced air draft controls on the furnace.

Manual Draft: If you selected Manual draft, you control the burn rate of your ENERGY KING Wood/Coal Furnace.

- For a higher burn rate, turn the manual draft spin dial to the left.
- For a lower burn rate, turn the manual draft spin dial to the right.
- The manual draft spin dial can be set to any position between high and low to achieve the desired rate of burn for your home.

Refueling

To refuel the wood fire in your ENERGY KING Wood/Coal Furnace:

1. Pull the sliding smoke baffle out.
2. Open the fuel loading door slowly: open the door about 1"-2" then wait about 10 seconds before opening fully. *Never stand in front of the fuel loading door when refueling; always stand to the side.*
3. Rake the red-hot embers over the grates evenly.
4. Put a few smaller pieces of wood on the coals first, and then load the furnace with larger pieces of wood.
5. Close the fuel loading door and sliding smoke baffle.

Operation

BURN AIR-DRIED WOOD, OR ANTHRACITE OR BITUMINOUS COAL ONLY

All home chimneys and hookups are different. After a few fires, you will find the best way to start a fire in your ENERGY KING Wood/Coal Furnace.

You will get the best efficiency when you add only the amount of coal needed for a 6 to 8 hour burn. Note: A full load is not always the best solution for your needs.

Burning Coal

Burning coal will provide a lesson in patience. Take the time necessary to experiment and understand the operation of your ENERGY KING Wood/Coal Furnace.

Please keep the following points in mind when burning coal:

1. A Barometric draft control in the chimney connector **must** be used when burning coal.
2. **Never** completely cover the live fire with fresh coal. Always leave a generous area of burning coal at the top and rear of the fire.
3. Always keep the ash pan clean. Coal firing produces much more ash than wood. These ashes must be removed often (possible daily) in order to avoid piling up too closely to the grates.

Removal of the coal ash will allow for passage of primary air to the coal bed and prevent damage or warpage to the grates.

Dispose of ashes with care:

Ashes should be placed in a metal container with a tight fitting metal lid. The closed container of ashes should be placed on a noncombustible floor or on the ground, well away from all combustible materials, pending final disposal.

All coal contains small amounts of dangerous elements. Therefore it is essential that your coal ash be disposed of in municipally designated areas.

4. A coal fire should not be poked or broken up, as this tends to bring ash to the surface of the coal bed where it may fuse. If the ash fuses, clinkers will form. It may be necessary to remove all unburned material and ash from the burn chamber to remove the clinkers. These should be carefully removed using tongs, and always put into an airtight metal container.
5. If the fire goes out or does not hold overnight, check for the following:
 - a. Poor Draft
 - b. Incorrect damper settings.
 - c. Improper firing methods for the coal being used.
 - d. Coal is not sized to the furnace (see *Fuel Requirements – Coal*).
 - e. Ashes, if allowed to accumulate in the ash pan, will not allow the passage of required air for combustion. Keep the ash pan clean.

Operation

Starting a Coal Fire

1. Pull the sliding smoke baffle (located above the fuel loading door) out to open.
2. Place a small amount of crumpled paper in the center of your ENERGY KING Wood/Coal Furnace. Crisscross a couple of handfuls of dry, 3/4" thick kindling wood, then several small pieces of firewood. Wait until the wood fire is established with hot, red embers before adding coal.

Be sure the sliding smoke baffle is fully open.

3. It will take 5 to 10 minutes for the wood fire to establish itself. Once you have some red-hot burning embers, add several small shovels of coal over the wood coals until you have a 2"-3" bed of burning coals. Be sure to give each small layer about 5-10 minutes to ignite before covering it with the next layer of coal.

4. After the coal fire is established and spread throughout the burn chamber, gently shake the grate until ashes fall in the ash removal pan. Add larger amounts of coal to build up the coal bed.

Never overload your burn chamber. Do not load coal above the top of the firebrick.

5. Push in the sliding smoke baffle after loading your ENERGY KING Wood/Coal Furnace and your fire is established.
6. The burning time is controlled totally by the draft controls on the furnace. Allow your ENERGY KING Wood/Coal Furnace to operate with draft controls fully open for approximately 15 minutes or until the fresh coal ignites. When the coal is properly ignited, adjust the thermostat accordingly.

Check the fire periodically to make sure it is spreading throughout the coal bed.

Refueling / Recharging

To refuel/recharge the anthracite coal fire in your ENERGY KING Wood/Coal Furnace:

1. Pull the sliding smoke baffle out.
2. Gently shake the grates down
3. Open the fuel loading door slowly: open the door about 1"-2" then wait about 15 to 20 seconds before opening fully.

When recharging, fresh coal tends to give off large quantities of volatile gas which may accumulate and possibly ignite, causing a backpuff. Always open the fuel loading door slowly to prevent backpuffing.

Never stand in front of the fuel loading door when refueling; always stand to the side.

4. If the coal fire has died down before recharging, a fresh supply of kindling will need to be added. Only add fresh coal to a deep, hot bed of coals.
5. Spread fresh coal evenly over existing coal, leaving some hot coals exposed in the center of the burn chamber. Be careful not to smother your existing coals.

Never overload your burn chamber. Do not load coal above the top of the firebrick.

6. Close the fuel loading door and sliding smoke baffle.

Operation

Bituminous Recharging

Because bituminous coal has higher sulfur content, bituminous recharging is slightly different from anthracite recharging.

To refuel/recharge the bituminous coal fire in your ENERGY KING Wood/Coal Furnace:

1. Pull the sliding smoke baffle out.
2. Gently shake the grates down
3. Open the fuel loading door slowly: open the door about 1"-2" then wait about 15 to 20 seconds before opening fully.

When recharging, fresh coal tends to give off large quantities of volatile gas which may accumulate and possibly ignite, causing a backpuff. Always open the fuel loading door slowly to prevent backpuffing.

Never stand in front of the fuel loading door when refueling; always stand to the side.

4. If the coal fire has died down before recharging, a fresh supply of kindling will need to be added. Only add fresh coal to a deep, hot bed of coals.
5. Push the hot coals to the rear of the burn chamber and position fresh coal on the grate in front of the banked coal. Be careful not to smother your existing coals.

Never overload your burn chamber. Do not load coal above the top of the firebrick.

6. Close the fuel loading door and sliding smoke baffle.

Banking

Banking allows you to recharge your coal fire in such a manner as to retain a hot coal bed throughout the night.

Approximately one hour before retiring for the night, push the coals to the rear of the burn chamber with the coal tapered down in the front.



Be careful not to smother your existing coals.

Never overload your burn chamber. Do not load coal above the top of the firebrick.

Maintenance

Periodic maintenance is required to continue the performance of your ENERGY KING Wood/Coal Furnace. As with any solid-fuel heating appliance, the need for and frequency of cleaning depends on the amount and quality of fuel burned, the quality of the fire, and the length of time since the last cleaning. Weekly cleaning may be required in warmer weather, whereas monthly cleaning may be enough in colder weather.

Before the first fire of each new heating season, check all installations and accessories to ensure a safe burning process.

	Risk of electric shock. Disconnect power at the service panel or breaker box before servicing ENERGY KING Wood/Coal Furnace.
	Keep the area around the ENERGY KING Wood/Coal Furnace clean and free of dust and debris.

Creosote – Formation and Need for Removal

When wood is burned slowly, it produces tar and other organic vapors, which combine with expelled moisture to form creosote. The creosote vapors condense in the relatively cool chimney flue of a slow-burning fire. As a result, creosote residue accumulates on the flue lining. When ignited, this creosote makes an extremely hot fire, the results of which can be tragic.

Check daily for creosote build up until experience shows how often cleaning is necessary. The chimney connector and chimney should be inspected at least twice monthly during the heating season to determine if a creosote buildup has occurred. If creosote has accumulated, it should be removed to reduce the risk of a chimney fire.

Be aware that the hotter the fire, the less creosote is deposited, and that weekly cleaning may be necessary in mild weather, even though monthly cleaning may be enough in the coldest months.

Have a clearly understood plan to handle a chimney fire.

Disposal of Ashes

Ashes should be placed in a metal container with a tight fitting metal lid. The closed container of ashes should be placed on a noncombustible floor on the ground, well away from all combustible materials, pending final disposal.

If the ashes are disposed of by burial in soil or otherwise locally dispersed, they should be retained in the closed container until all ash and cinders have thoroughly cooled. Do not place any other waste materials in this container.

All coal contains small amounts of dangerous elements. Therefore it is essential that your coal ash be disposed of in municipally designated areas.

NOTE: EMBERS REMAIN HOT FOR MANY DAYS. STORE IN A SAFE PLACE AWAY FROM COMBUSTIBLES.

Never use a conventional vacuum cleaner or a shop vacuum to remove ashes from a solid-fuel heating appliance. Ashes remain hot for many days, and when trapped in a conventional vacuum can cause a fire hazard. Only use a vacuum designed for the safe cleaning and removal of ashes.

Maintenance

Gasket Replacement

The cast iron fuel loading and ash removal doors of your ENERGY KING Wood/Coal Furnace are equipped with gaskets to ensure safe operation and an airtight seal. When these gaskets become worn or damaged, you will need to replace them.

To replace the gaskets you will need 3/4-inch, high temperature rope gasket, available from your ENERGY KING dealer or hardware store.

1. Remove the door and lay it face down on a clean, flat surface.
2. Find the ends of the gasket and pull it off.
3. Using a screwdriver, remove any excess gasket cement from the gasket channel.
4. If desired, a small drop of gasket cement may be applied to the corners of the gasket channel.
5. Lay the new door gasket in the channel, cutting off any excess gasket rope.
6. Reattach the door. If gasket cement was applied, keep the door closed until the cement has fully dried.

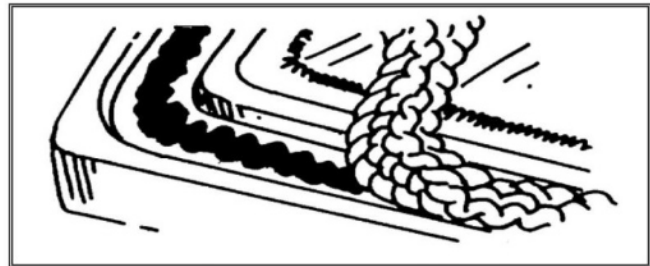

Routine Maintenance

Please use the following timeline as a guide for determining how much maintenance your ENERGY KING Wood/Coal Furnace requires to operate at peak performance. Failure to clean and maintain this Furnace as indicated can result in poor performance and safety hazards.

Please use *Appendix D: Purchase & Service Record* to keep a record of your maintenance and service practices. In the event of a warranty claim, we may request a copy of this record.



Inspect flue pipes, joints and seals regularly to ensure that smoke and flue gases are not drawing into the home.

Daily

Until a pattern of cleaning requirement is established, inspect and, if necessary, clean the following components daily:

- Fuel Supply, refilling as necessary.
- Flue Pipes, including joints and seals, should be inspected to ensure that smoke and flue gases are not drawn in and circulated by the air-circulation system.
- Ash removal pan should be emptied and cleaned regularly. Ash content is a good indicator of fuel efficiency and quality. High quality fuel will produce less ash than lower quality fuel. Never allow ash to build up to the level of the grates.

Maintenance

Every 2 – 3 Days / Weekly

Once a pattern of cleaning requirement is established, the following components should still be monitored on a regular basis:

- Burn chamber
- Ash removal pan
- Flue pipes, joints and seal

Monthly

The air filter on your ENERGY KING Wood/Coal Furnace should be monitored on a regular basis and replaced when necessary.

Seasonally / Every 3 Months / After every 1 – 2 Tons of fuel burned

Until you are familiar with how ash and creosote accumulate with your operating practices, we recommend inspecting your ENERGY KING Wood/Coal Furnace at least once per ton of fuel burned. Particular attention should be given to:

- Draft Control system (motors, blowers, etc.)
- Gaskets (Fuel loading and Ash Removal Doors)
- Air Filter
- Fresh air intake
- Chimney

Annual / Spring Shutdown



Cleaning the flue pipe and chimney is especially important at the end of the heating season to minimize corrosion during the summer months caused by accumulated ash.

It is important to give the entire ENERGY KING Wood/Coal Furnace a thorough cleaning:

- Your venting system should be inspected and cleaned annually. Clean and remove fly ash from chimney connector, flue pipes and chimney. Soot buildup should be removed to prevent the risk of a chimney fire and to minimize corrosion during the summer months.
- Scoop out any unburned fuel from the burn chamber, and empty and clean the burn chamber and ash removal pan.
 - Do not allow fuel or ash to sit in the ENERGY KING Wood/Coal Furnace over the summer months. Fuel and ash can accumulate moisture over the summer months having a corrosive effect on metal and cast iron parts, and causing the fuel to mold.

Failure to clean and maintain this Furnace as indicated can result in poor performance and safety hazards.

Please use *Appendix D: Purchase & Service Record* to keep a record of your maintenance and service practices. In the event of a warranty claim, we may request a copy of this record.

Remember: A clean Furnace burns efficiently and will remain trouble free!

Troubleshooting Guide

⚠ DANGER

Risk of electric shock. Disconnect power at the service panel or breaker box before servicing ENERGY KING Wood/Coal Furnace.

Many problems in the ENERGY KING Wood/Coal Furnace can be traced to a few commonplace causes and are easily fixed. Before making any repairs or replacing any components, be sure to check for these common problems:

Fuel

- Wet or Dirty fuel

Solution: Empty and clean the burn chamber. Refill using only high quality, clean, dry fuel as outlined in *Fuel Requirements*.

Improper Draft

- Too little or too much draft
- Insufficient combustion air

Solution: Adjust the draft controls and observe until you determine which settings are most appropriate for your usage. See *Operation* for further information.

Ash buildup in the ash removal pan

Solution: Be sure to maintain your ENERGY KING Wood/Coal Furnace's cleanliness by emptying the ash removal pan regularly. See *Maintenance* for further information.

We also recommend establishing a routine of inspecting gaskets and replacing when necessary. Maintaining your ENERGY KING Wood/Coal Furnace's cleanliness and adjusting the draft controls will remedy many problems.



Troubleshooting Guide

Detailed Troubleshooting

Once you have exhausted the above common problems, if you are still experiencing trouble with your ENERGY KING Wood/Coal Furnace, you may wish to consult the following list of problems, or consult with your ENERGY KING dealer for further assistance.

Problem(s)	Cause(s) / Solution(s)
Fire won't start or starts but won't stay lit, or does not hold out overnight	<ul style="list-style-type: none">• Make sure all furnace doors are closed tightly and all gaskets are in good condition.• Ashes, if allowed to accumulate in the ash removal pan, will block the passage of combustion air. Verify that your ash removal pan is clean. Never allow ashes to build up to the level of the grates.• Your exhaust or combustion air systems may be blocked. Verify all vents and pipes are free from obstruction and the draft controls are operating correctly.• Check your chimney for downdraft caused by taller surrounding trees or buildings. The chimney may have to be extended or a chimney vent cap installed. Please contact your ENERGY KING dealer or heating contractor.
Fire is weak, lazy, or dirty, or startup is slow or smoky	<ul style="list-style-type: none">• Your fire may need more combustion air. Increase the amount of combustion air by adjusting your draft controls.• Your exhaust or combustion air systems may be blocked. Verify all vents and pipes are free from obstruction and the draft controls are operating correctly.• Your home may have a negative pressure. If your home is too airtight, the ENERGY KING heating appliance cannot get enough combustion air to burn properly. You may need to bring outside air to the ENERGY KING heating appliance. Please contact your ENERGY KING dealer or heating contractor.• Check your chimney for downdraft caused by taller surrounding trees or buildings. The chimney may have to be extended or a chimney vent cap installed. Please contact your ENERGY KING dealer or heating contractor.
Smoke is visible or you smell fumes in your home	<ul style="list-style-type: none">• Make sure all doors are closed tightly and all gaskets are in good condition.• Your exhaust or combustion air systems may be blocked. Verify all vents and pipes are free from obstruction and the draft controls are operating correctly.• Your venting may be improperly installed. If the ENERGY KING heating appliance is smoking from vents, ducts, or from the draft controls, immediately shut down the ENERGY KING heating appliance, ventilate the area, and contact your ENERGY KING dealer or heating contractor.

Troubleshooting Guide

Problem(s)	Cause(s) / Solution(s)
Excessive creosote	<ul style="list-style-type: none"> • During warmer weather, you may need to adjust your firing practices. For maximum efficiency and minimum emissions, try shorter, hotter fires rather than large, slow-burning fires. • Your venting may be improperly installed. Verify that the ENERGY KING heating appliance is vented according to instructions found in the <i>Installation</i> section. Please contact your ENERGY KING dealer or heating contractor.
Excessive Fire	<ul style="list-style-type: none"> • There may be too much combustion air. Adjust the Furnace draft controls. • The chimney draft may be excessive. Adjust the barometric damper to maintain flue draft settings from 0.04" to 0.06" of water column. Do not operate with a flue draft exceeding .06" (14.95 Pa) water column.
Poor combustion or difficulty maintaining a "pilot" fire	<ul style="list-style-type: none"> • Check the quality of your fuel. Refer to <i>Fuel Requirements</i>. • Your fire may need more combustion air. Increase the amount of combustion air by adjusting your draft controls. • Your home may have a negative pressure. If your home is too airtight, the ENERGY KING heating appliance cannot get enough combustion air to burn properly. You may need to bring outside air to the ENERGY KING heating appliance. Please contact your ENERGY KING dealer or heating contractor.
Too much ash	<ul style="list-style-type: none"> • Check the quality of your fuel. Refer to the <i>Fuel Requirements</i> section.
Ash, soot, or fuel dust in the home	<ul style="list-style-type: none"> • Verify all Furnace doors are closed tightly and all gaskets are in good condition. • Always be sure to handle ashes and fuel with care and open doors slowly. • Ashes can escape from conventional vacuums. We recommend using a vacuum designed for ashes. • Be sure to check the exhaust system for leaks and repair as necessary. • Your home may have a negative pressure. If your home is too airtight, the ENERGY KING heating appliance cannot get enough combustion air to burn properly. You may need to bring outside air to the ENERGY KING heating appliance. Please contact your ENERGY KING dealer or heating contractor.

Troubleshooting Guide

Problem(s)	Cause(s) / Solution(s)
Partially burned or unburned fuel in the combustion area	<ul style="list-style-type: none"> • More air for proper combustion may be needed. Verify that your draft controls are working properly and that your exhaust and combustion air systems are clean and free from obstruction.
The ENERGY KING heating appliance burns too much fuel, or the fuel burns off too quickly	<ul style="list-style-type: none"> • The chimney draft may be excessive. Adjust the barometric damper to maintain flue draft settings from 0.04" to 0.06" of water column. Do not operate with a flue draft exceeding .06" (14.95 Pa) water column.
The ENERGY KING heating appliance is overheating or is burning without regard to the thermostat	<ul style="list-style-type: none"> • Your ENERGY KING heating appliance may have been installed incorrectly. Please contact your ENERGY KING dealer or heating contractor. • The thermostat or thermostat wiring may be faulty. Please contact your ENERGY KING dealer or heating contractor.
The ENERGY KING heating appliance will not heat the whole house or doesn't produce as much heat as when first installed	<ul style="list-style-type: none"> • Verify that the venting and draft control systems are clean and free from obstruction. Verify that all heat delivery systems are operating correctly.
The circulation blower runs continuously, cycles on and off too much, or won't run at all	<ul style="list-style-type: none"> • Make sure the Fan/limit Control is set on <i>Auto</i> and is not on <i>Manual</i>. • The fan/limit control ON/OFF temperature settings may need to be adjusted. (ON/OFF temperatures may be set too close together). Please see <i>Assembly</i> for recommended fan/limit control settings. • Your furnace may have a faulty fan/limit control or blower motor. Please contact your ENERGY KING dealer for replacement parts.
The ENERGY KING heating appliance has power but is not responding	<ul style="list-style-type: none"> • Check the power supply for adequate voltage. See the <i>Installation</i> section for power supply requirements. • Your ENERGY KING may have been installed incorrectly. Please contact your ENERGY KING dealer or heating contractor.
The user is shocked when touching the ENERGY KING heating appliance	<ul style="list-style-type: none"> • Your ENERGY KING may not have been properly grounded or may have loose wires or wiring components. Disconnect power to the ENERGY KING at the breaker box or service panel and verify all connections. Please contact your ENERGY KING dealer or heating contractor. • Your ENERGY KING heating appliance may have experienced a power surge or power short. Please contact your ENERGY KING dealer or heating contractor.

Appendix A: Wiring Diagrams

A-1: Automatic Draft Wiring Diagram

ENERGY KING Wood/Coal Furnace Models EK365/EK385/EK480 Wiring Diagram - Automatic Draft Field Wiring Use Copper Wire Only

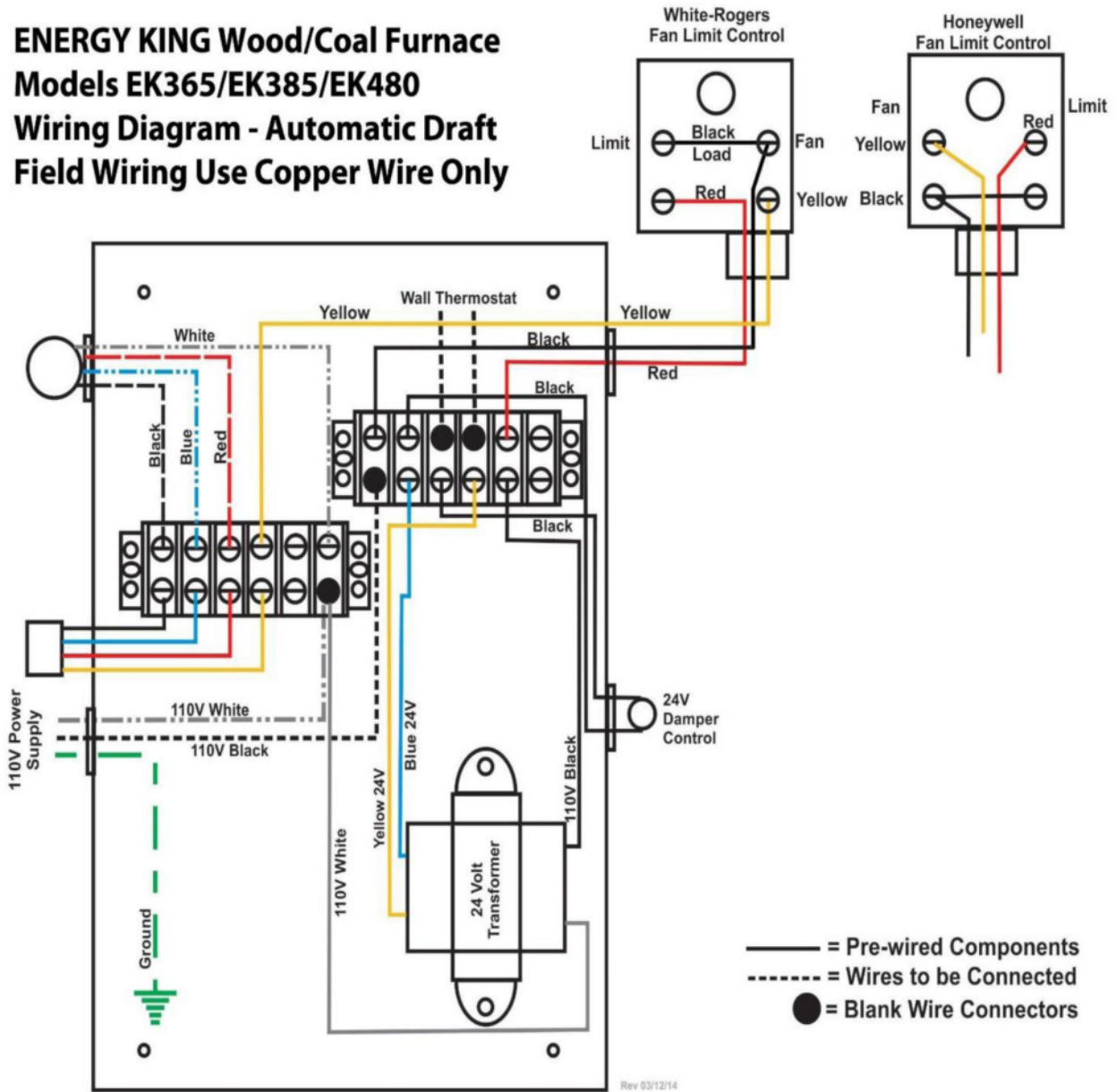

Appendix A: Wiring Diagrams

A-2: Forced Air Draft Wiring Diagram

ENERGY KING Wood/Coal Furnaces Models EK365/EK385/EK480 Wiring Diagram - Forced Draft Field Wiring Use Copper Wire Only

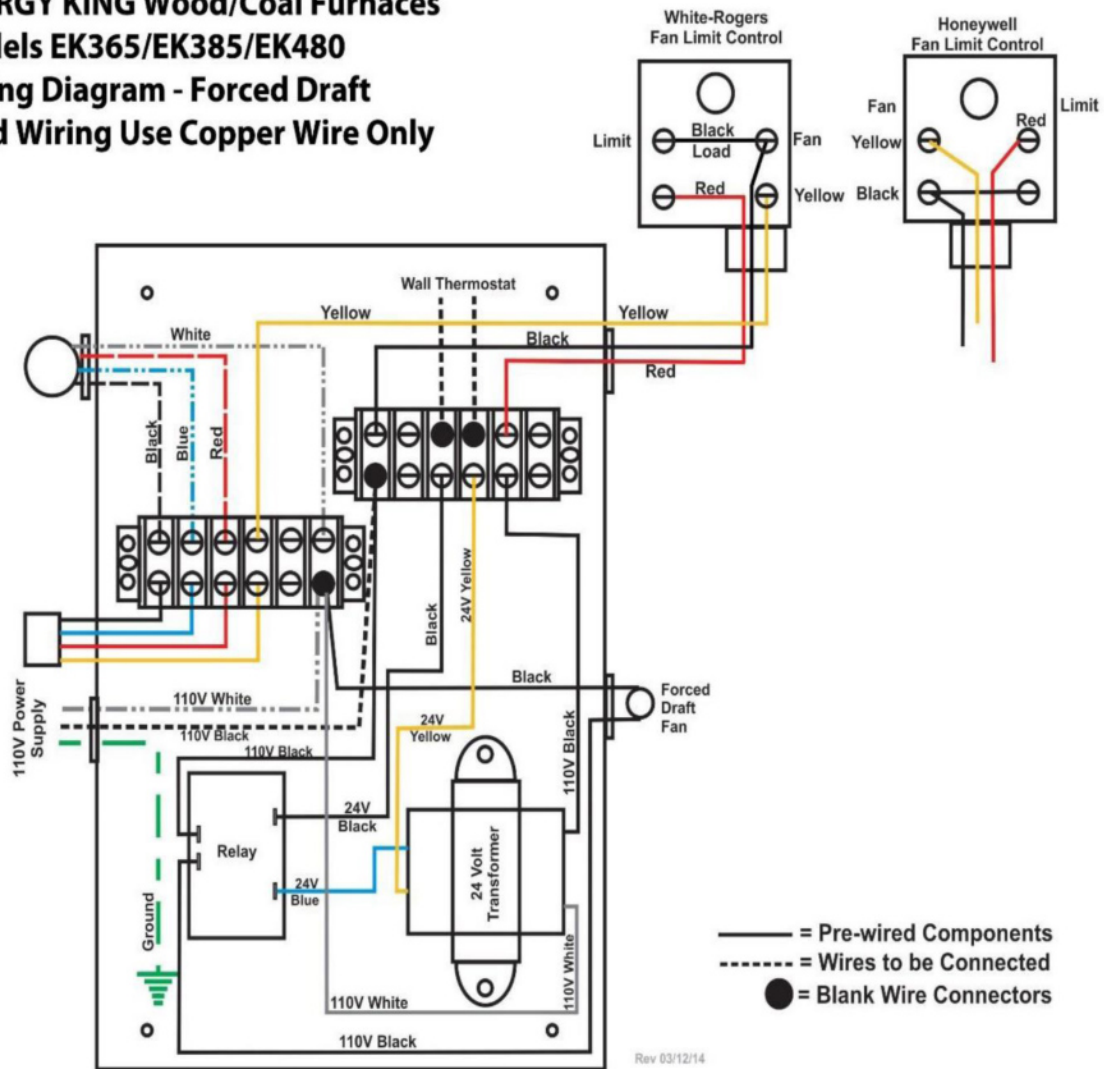

Appendix A: Wiring Diagrams

A-3: Manual Draft Wiring Diagram

ENERGY KING Wood/Coal Furnaces Models EK365/EK385/EK480 Wiring Diagram - Manual Draft Field Wiring Use Copper Wire Only

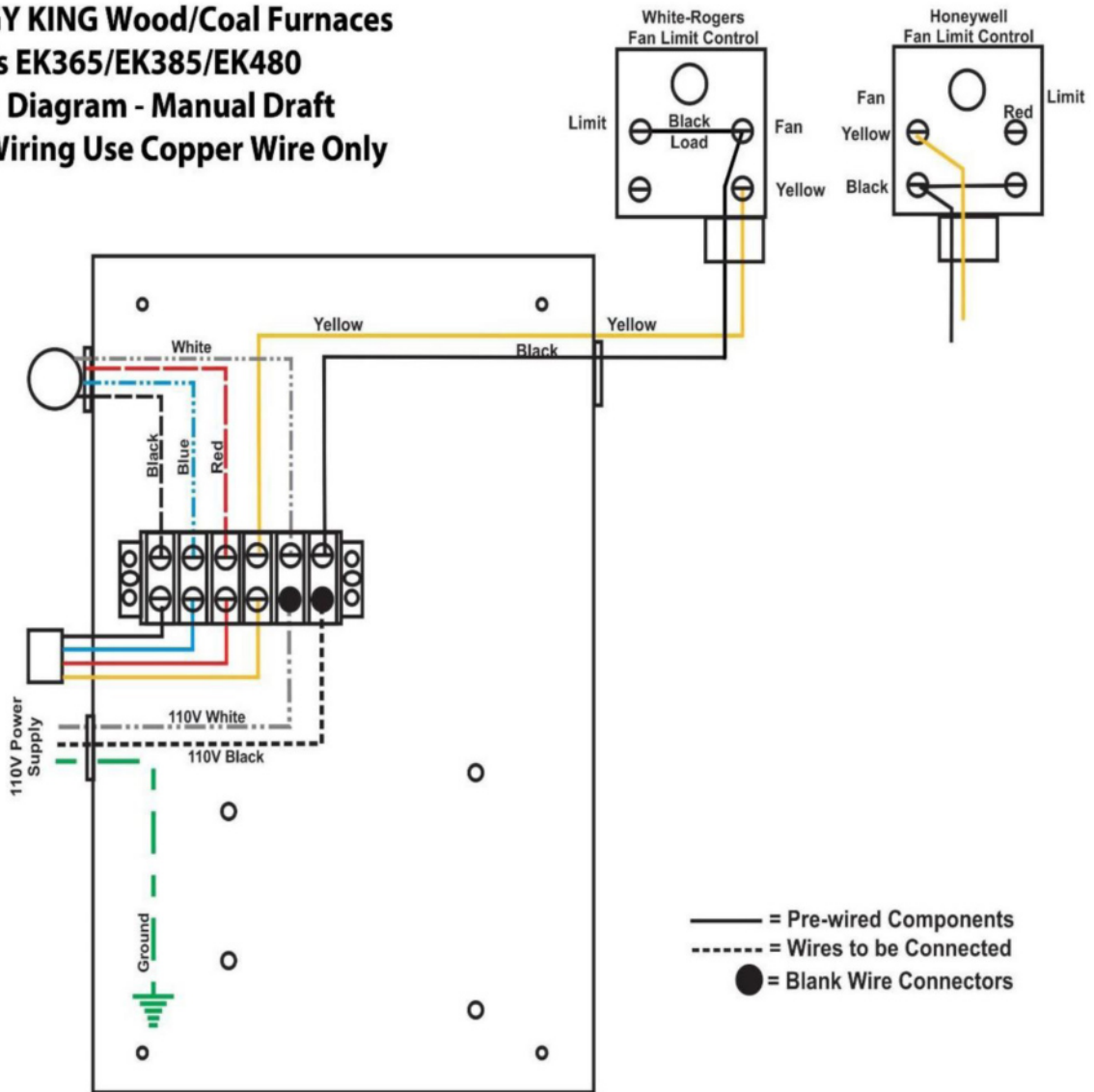

Appendix B: Filter Box Assembly Schematic

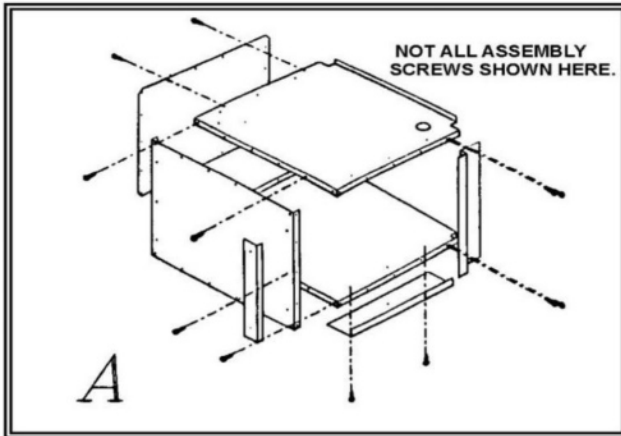

CAUTION
 THE FILTER MUST BE REMOVED IF THE FAN IS INOPERABLE FOR ANY REASON, INCLUDING POWER FAILURE. THIS WILL PREVENT OVERHEATING OF THE MOTOR.

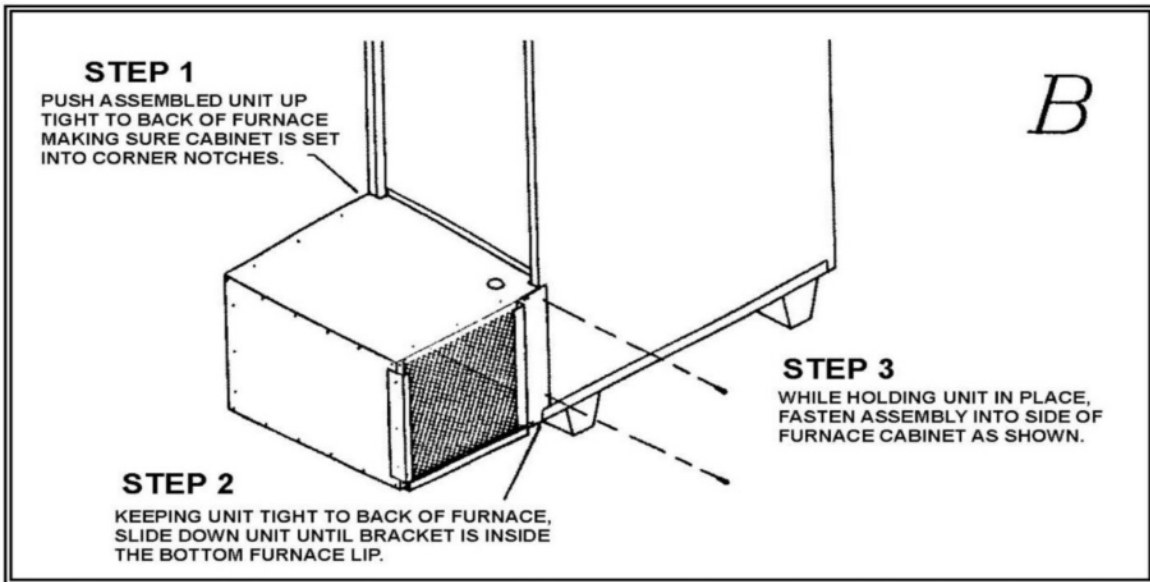

THE AIR FILTER MUST BE NON-COMBUSTIBLE.

Non-combustible air filters are available from your **ENERGY KING** dealer.

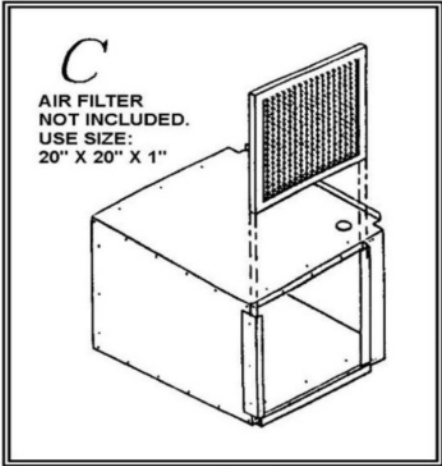



Appendix C: Parts List

Parts Number	Parts Description
CAS70770	EK ROCKER GRATE
CAS70794	EK DRAFT KNOB
CAS70797	EK ASH DOOR
FUR50547	CONTROL BOX COVER ONLY
FUR50548	CONTROL BOX ONLY
FUR50917	EK480 DAMPER ROD
FUR50918	EK385 DAMPER ROD
FUR50919	EK365 DAMPER ROD
FUR50920	EK385 DAMPER PLATE
FUR50921	EK365 DAMPER PLATE
FUR50922	EK480 DAMPER PLATE
FUR50927	SHAKER EXTENSION
FUR70448	CIRCULATION MOTOR/BRACKE/CAP ONLY
FUR70449	SELECTOR SWITCH BRD BAR-FLAT
FUR70453	TERMINAL BRD BAR-FLAT
FUR70462	EK385 DRAFT FAN MOUNT
FUR70464	EK365/EK480 DRAFT TUBE
FUR70465	EK385 DRAFT TUBE
FUR70466	EK365/EK480 DRAFT FAN MOUNT
FUR70793	EK385 CUT TUBE
FUR70802	YOKE FOR GRATE SHAKER
FUR70807	FURNACE INSULATION
FUR71093	EK385 GLASS
FUR80111	EK365 SHAKER HANDLE UPGRADE
FUR80115	FILTER BOX
HAR70450	EK 24-V TRANSFORMER
HAR70451	TERMINAL BRD 6 POLE
HAR70452	TERMINAL BRD BAR-ANGLE
HAR70545	WALL THERMOSTAT
HAR70784	ACTUATOR DAMPER MOTOR
HAR70813	3 SPEED SWITCH ONLY
HAR70814	EK385 KNOB HI/LOW
HAR71094	RELAY FOR FORCED AIR
HAR71095	



Appendix D: Purchase & Service Record

ANNUAL INSPECTION BY QUALIFIED PROFESSIONAL IS RECOMMENDED.

Purchase & Installation Record			
MODEL*	SERIAL NUMBER*	PURCHASE DATE	INSTALLATION DATE
DEALER		INSTALLER	
ADDRESS		ADDRESS	
CITY / STATE / ZIP		CITY / STATE / ZIP	
CONTACT		CONTACT	
PHONE NUMBER		PHONE NUMBER	
COMMENTS			

*Model and serial number are located on the label on the lower left front of the unit.

Service & Maintenance Record		
DATE	TECHNICIAN	DESCRIPTION OF WORK DONE

Have you completed & returned your warranty card? _____ Date Mailed: _____

Has Dealer / Installer gone over the operation and maintenance of appliance? _____



Appendix E: Warranty Claim Procedures

We make every effort to ensure that all **ENERGY KING** heating appliances and components adhere to our strict standards for quality and safety. However, should you receive a product or component that doesn't function as intended, please follow the instructions below for making a warranty claim. We will replace or repair the part, as outlined in the applicable warranty, as soon as possible to keep your **ENERGY KING** heating appliance functioning safely and efficiently as intended.

Parts

To make a warranty claim on faulty parts provided with an ENERGY KING heating appliance, please contact your ENERGY KING dealer.

If your ENERGY KING dealer is unavailable:

1. Please complete a *Warranty Claim Form* and return it to us. All warranty claim requests **must** be made in writing; **verbal warranty claim requests will not be processed.**

The following information is **required** when submitting a warranty claim:

- Model number
- Serial Number
- Purchase Date
- Purchaser Name, Address, and Telephone

2. Additionally, if you have not mailed in your *Warranty Registration Card*, we will require a completed *Warranty Registration Card* to be returned to us along with dated proof of purchase (i.e. a copy of your receipt or invoice).

We may also request a copy of the Service & Maintenance Log located in the Appendix of your Owner's Manual.

Without this information, we will not be able to complete your requested warranty claim.

Once we receive your completed *Warranty Claim Form* and *Warranty Registration Card*, we will ship a replacement for the faulty part(s). All transportation charges are to be paid for by the purchaser. However, if a faulty part is to be returned to us, we will provide return-shipping via a call-tag.

Units

To make a warranty claim on a faulty ENERGY KING heating appliance, please contact your ENERGY KING dealer.

If your ENERGY KING dealer is unavailable, please contact us at (715) 720-1794 for instructions.

When contacting Energy King for a warranty claim on a faulty ENERGY KING heating appliance, please have the following information ready:

- Model number
- Serial Number
- Purchase Date
- Purchaser Name, Address, and Telephone

Additionally, if you have not mailed in your *Warranty Registration Card*, we will require a completed *Warranty Registration Card* to be returned to us along with dated proof of purchase (i.e. a copy of the receipt or invoice).

We may also request a copy of the Service & Maintenance Log located in the Appendix of your Owner's Manual.

Without this information, we will not be able to complete your requested warranty claim.

All transportation charges are to be paid for by the purchaser.

Energy King reserves the right to refuse any warranty claim, subject to the terms, conditions and restrictions of the warranty agreement found in the corresponding ENERGY KING installation & operation manual.



Appendix E: Warranty Claim Procedures

ENERGY KING® Solid-Fuel Heating Appliances Warranty Claim Form

For all ENERGY KING warranty claims, please complete this form **IN FULL** and return it to *Energy King*, via fax at **608-768-8433** or via postal mail at:
Energy King, 325 South Park St., Reedsburg, WI 53959

DEALER:		PURCHASER:	
ATTENTION:		ATTENTION:	
ADDRESS 1:		ADDRESS 1:	
ADDRESS 2:		ADDRESS 2:	
CITY, ST, ZIP		CITY, ST, ZIP:	
TELEPHONE:		TELEPHONE:	
FAX:			
EMAIL:			

Model:	Serial No:	Date of Purchase:	Date of Failure:	Date of Repair:
Description of Failure / Repairs Made (please be specific):				
Signature:				Date:

PARTS REPLACED			
QTY	PART NO. (if applicable)	DESCRIPTION	Return Faulty?
Miscellaneous:			

Copies of invoices / receipts are required for all credits claimed on this form.

Energy King reserves the right to refuse any warranty claim, subject to the terms, conditions and restrictions of the warranty agreement found in the corresponding ENERGY KING installation & operation manual.

LIMITED WARRANTY

Who is covered?

You are covered under this warranty if you are the original purchaser of a new ENERGY KING solid-fuel heating appliance and your purchase was made through an authorized distributor/dealer of the ENERGY KING solid-fuel heating appliance.

How long does the coverage last?

The term of this warranty begins on the date of original purchase as evidenced by your purchase receipt, subject to the terms, conditions and restrictions of this agreement. Coverage is extended to you for the following time periods:

- **Burn chamber.** The burn chamber is warranted for six (6) years on a prorated basis. The replacement value will decrease each year until the maximum life of the warranty exhausts any replacement value. Replacement value is reduced according to the following schedule and will be calculated on the cost of the burn chamber at the time the part is repaired or replaced. We will provide you with a credit to be applied towards the cost of the repair or replacement part.

Year 1	Full Warranty
Year 2	80% Credit
Year 3	60% Credit
Year 4	40% Credit
Year 5	25% Credit
Year 6	15% Credit

- **Castings.** The castings are warranted for one (1) year and include the fuel loading door, ash removal door, hearth plates, and grates.
- **Electrical Components.** The electrical components are warranted for one (1) year and include, but are not limited to, the draft damper control motor or combustion fan, and all components of the control box.

What is covered by this warranty?

This warranty covers any defects in materials or workmanship in your new ENERGY KING solid-fuel heating appliance.

What is not covered by this warranty?

This limited warranty does not apply:

- If your appliance has not been installed, operated and maintained in strict accordance with instructions provided in the Installation, Operation and Maintenance Manual.
- If any part has been damaged in shipment, modified, altered, tampered with, abused, or has been subject to accident or misuse.
- If your appliance has been altered or repaired in a manner which, in our sole judgment, affects its performance, stability or reliability.
- If parts not made or supplied by us have been used in connection with the appliance, if in our sole judgment, such use affects its performance, stability or reliability.
- To transportation charges on appliances and appliance parts submitted for repair or replacement under this warranty.
- To expendable, replaceable or wear items, such as firebrick, gaskets/seals, paint, handles and other items that in our judgment are expendable, replaceable or wear items.
- To any heating system or systems to which the appliance may be attached.
- To any of the smoke pipes, heat pipes, chimney, hardware, ducting, vents, or other accessories used for the installation and venting or ducting of the appliance.

We are not responsible for installation and will not be liable in any respect under the terms of the warranty for injury or damage to the building structure in which the appliance has been installed, or to the person or persons and property therein, arising out of the use, or installation of the ENERGY KING appliance. The appliance must be installed in compliance with the state, local national building and fire codes and regulations of the area and in strict adherence to the Manufacturer's recommendations.



What will we do to correct problems?

We will repair, or at our option, replace any ENERGY KING solid-fuel heating appliance or appliance part, which upon inspection shows a defect in materials or workmanship.

How can you get service?

If warranty service is needed during the warranty period, notify your authorized ENERGY KING dealer. If there is no ENERGY KING dealer in your area, contact Energy King directly. Provide your name, address, phone number, serial number and model number of the furnace, date of purchase, name and address of installer and a description of the problem.

Disclaimer of Implied Warranties & Consequential Damages

Our obligation under this limited warranty, to the extent allowed by law, is in lieu of all warranties, implied or expressed, including implied warranties of merchantability and fitness for a particular purpose and any liability for incidental and consequential damages with respect to the sale or use of the items warranted. Such incidental and consequential damages shall include but not be limited to: transportation / freight charges, cost of installation, duty, taxes, charges for service or adjustment, loss of income, rental or substitute equipment, and expenses due to loss, damage, detention or delay in the delivery of equipment or parts resulting from acts beyond our control.

Some states do not allow the exclusion or limitation of incidental or consequential damages, or limitation of implied warranties, so the limitations or exclusions in this limited warranty may not apply to you.

NO EMPLOYEE OR REPRESENTATIVE OF Energy King IS AUTHORIZED TO CHANGE THIS LIMITED WARRANTY IN ANY WAY OR GRANT ANY OTHER WARRANTY UNLESS SUCH CHANGE IS MADE IN WRITING BY AN OFFICER OF Energy King AT ITS HOME OFFICE.

YOUR RESPONSIBILITY UNDER THE WARRANTY

It is your responsibility to ensure that the appliance is installed in compliance with local, state and national building and fire codes regulating installation and inspection.

It is your responsibility to complete the warranty card and return it to the address indicated within 30 days of the purchase. You must also keep your receipt as proof of date of purchase. Failure to do so will mean that you may not later make a claim under this warranty.

It is your responsibility to read the Installation, Operation & Maintenance Manual and to install, operate and maintain the appliance in accordance with all instructions and safety procedures. Failure to do so is a misuse of the appliance.

It is your responsibility to inspect the appliance and to have any part(s) repaired or replaced when continued operation would cause damage or excessive wear to other parts or cause a safety hazard.

It is your responsibility for any cost incurred by the distributor/dealer for travel to or transportation of the product for the purpose of performing a warranty obligation or inspection.



Energy King
325 South Park St.
Reedsburg, WI 53959
800-944-2516
Email: info@energyking.com
www.energyking.com



Supplement A: 24-V Wall Thermostat

The following document was prepared and published by Honeywell International for distribution with their models "T822K,L & T827K" wall thermostats.

It is reproduced here for reference purposes ONLY.

Product application

This thermostat provides control of:

- 24 Vac heating systems (T822)
- 750 mV or 12 Vdc heating systems (T827K)
- 24 Vac cooling systems (T822L)

System Types

- Gas or oil
- Warm air, hot water, high-efficiency furnaces, heat pumps, steam, gravity
- Normally opened hot water valves (T822K)
- 2-wire cooling systems (T822L)
- Normally closed hot water valves (T822L)

System Settings

- Heat, Off (select models only)

Specifications

Temperature Range

- 50° to 90°F (10° to 32°C)

Operating Ambient Temperature

- 0° to 120°F (-18° to 49°C)

Operating Relative Humidity

- 5% to 90% (non-condensing)

Dimensions (vertical model)

- 2.88W x 4.75H x 1.5D (inches)
- 73W x 121H x 38D (mm)

Dimensions (horizontal model)

- 4.75W x 2.88H x 1.5D (inches)
- 121W x 73H x 38D (mm)

Electrical Ratings

Terminal	Voltage (50/60Hz)	Running Current
W Heating	20-30 Vac	0.02-1.2 A
(Powerpile)	750 mVdc	100 mAdc
(DC Powered)	12 Vdc	.55 A
Y Cooling	20-30 Vac	0.02-1.2 A

Base installation

1. Pull wires through wire hole. Position base on wall, level and mark hole positions.
2. Drill holes (3/16" holes for drywall, 7/32" holes for plaster), then tap in supplied wall anchors.
3. Pull wires through base, position over anchors, and insert screws. Check level if desired, then tighten screws.

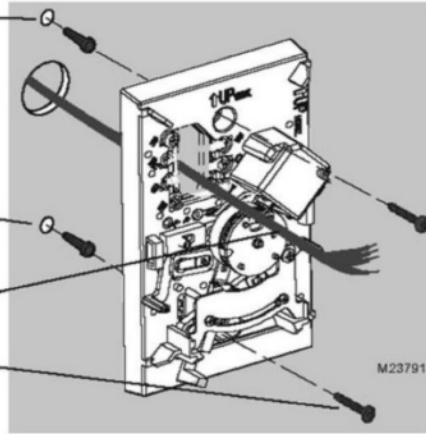

Wiring

1. Loosen screw terminals, insert bare wires beneath screws, then re-tighten screws.
2. Push any excess wire back into the wall opening
3. Plug the wall opening with nonflammable insulation to prevent drafts from affecting thermostat operation.

Terminal Designations

R Heating power. Connect to secondary side of heating system transformer.

W Heat relay.

Y Compressor or normally closed hot water valve. **

** T822L only

Wire specifications

Use 18-gauge thermostat wire. Shielded cable is not required.

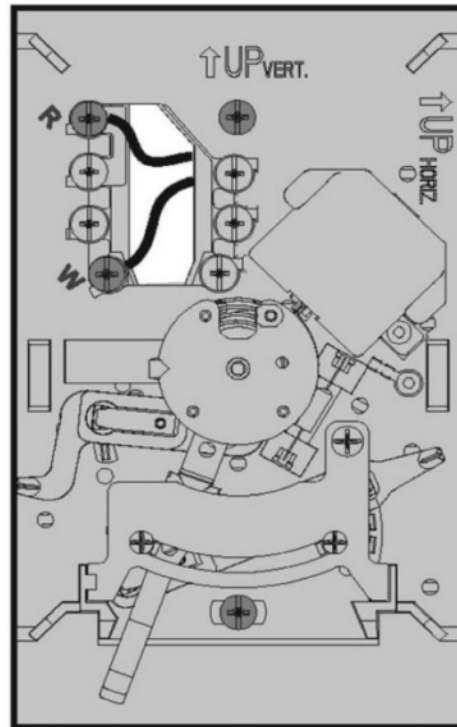

Set heat anticipator (model T822K only)

Move the adjustment arrow to the proper setting for your system (see table below).

Your system	Setting
Steam	1.2
Hot water heat	0.8
Warm air (high efficiency)	0.8
Warm air (standard)	0.4
Electric heat	0.3

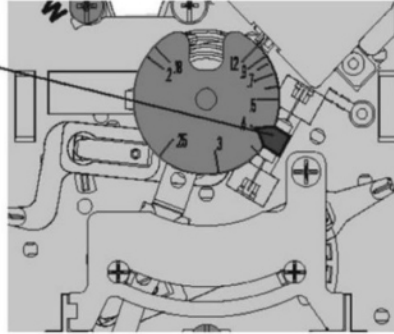

Thermostat mounting

Align the slots on the cover with tabs on the sides of the base, then push gently until the cover snaps into place.

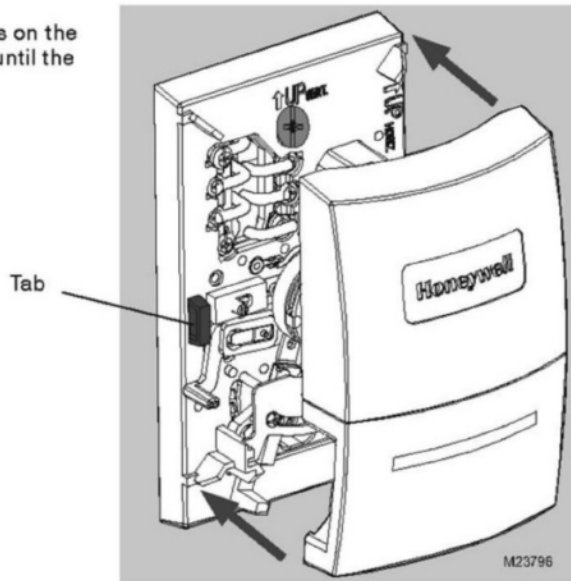

Operation

Temperature setting

Adjust to set desired indoor temperature.

System switch (select models)

- **Heat:** Controls the heating system.
- **Off:** All systems are off.

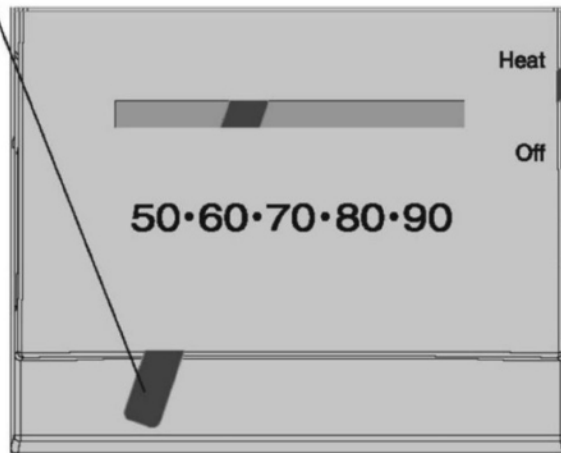

M24696

5-year limited warranty

Honeywell warrants this product to be free from defects in the workmanship or materials, under normal use and service, for a period of five (5) years from the date of purchase by the consumer. If at any time during the warranty period the product is determined to be defective or malfunctions, Honeywell shall repair or replace it (at Honeywell's option).

If the product is defective,

- return it, with a bill of sale or other dated proof of purchase, to the place from which you purchased it; or
- call Honeywell Customer Care at 1-800-468-1502.

Customer Care will make the determination whether the product should be returned to the following address:

Honeywell Return Goods, Dock 4 MN10-3860, 1885 Douglas Dr. N., Golden Valley, MN 55422, or whether a replacement product can be sent to you.

This warranty does not cover removal or reinstallation costs. This warranty shall not apply if it is shown by Honeywell that the defect or malfunction was caused by damage which occurred while the product was in the possession of a consumer.

Honeywell's sole responsibility shall be to repair or replace the product within the terms stated above. HONEYWELL SHALL NOT BE LIABLE FOR ANY LOSS OR

DAMAGE OF ANY KIND, INCLUDING ANY INCIDENTAL OR CONSEQUENTIAL DAMAGES RESULTING, DIRECTLY OR INDIRECTLY, FROM ANY BREACH OF ANY WARRANTY, EXPRESS OR IMPLIED, OR ANY OTHER FAILURE OF THIS PRODUCT. Some states do not allow the exclusion or limitation of incidental or consequential damages, so this limitation may not apply to you.

THIS WARRANTY IS THE ONLY EXPRESS WARRANTY HONEYWELL MAKES ON THIS PRODUCT. THE DURATION OF ANY IMPLIED WARRANTIES, INCLUDING THE WARRANTIES OF MERCHANTABILITY AND FITNESS FOR A PARTICULAR PURPOSE, IS HEREBY LIMITED TO THE FIVE-YEAR DURATION OF THIS WARRANTY. Some states do not allow limitations on how long an implied warranty lasts, so the above limitation may not apply to you.

This warranty gives you specific legal rights, and you may have other rights which vary from state to state.

If you have warranty questions, please write Honeywell Customer Relations, 1985 Douglas Dr., Golden Valley, MN 55422 or call 1-800-468-1502. In Canada, write Retail Products ON15-02H, Honeywell Limited/Honeywell Limitée, 35 Dynamic Drive, Toronto, Ontario M1V4Z9.

Need Help?

For assistance with this product please visit <http://yourhome.honeywell.com>
or call Honeywell Customer Care toll-free at 1-800-468-1502

Besoin d'aide?

Pour obtenir de l'aide et apprendre à faire fonctionner votre produit
Honeywell, veuillez consulter le site Web <http://yourhome.honeywell.com>
ou vous adresser aux Services à la clientèle de Honeywell en composant le
1 800 468-1502

¿Necesita ayuda?

Consulte sobre este producto en <http://yourhome.honeywell.com>
o llamando sin cargo a atención al cliente de Honeywell 1-800-468-1502

Automation and Control Solutions

Honeywell International Inc.

1985 Douglas Drive North

Golden Valley, MN 55422

<http://yourhome.honeywell.com>

Honeywell Limited-Honeywell Limitée

35 Dynamic Drive

Toronto, Ontario M1V 4Z9



Printed in U.S.A. on recycled
paper containing at least 10%
post-consumer paper fibers.

Honeywell

© U.S. Registered Trademark.
© 2007 Honeywell International Inc.
69-1945EFS—1 M.S. Rev. 04-07



Supplement B: Fan/Limit Control

The following document was prepared and published by Honeywell International for distribution with their models L4064B2640/B fan limit controls.

It is reproduced here for reference purposes ONLY.

Honeywell

L4064 COMBINATION WARM AIR FAN AND LIMIT CONTROLLERS ARE SUITABLE FOR ALL TYPES OF FORCED AIR HEATING SYSTEMS.

- L4064A-F,J and R turn fan on and off according to plenum temperature.
- L4064T,W,Y and have a bimetal heater switch which turns fan on approximately 20 to 90 seconds under normal conditions after the thermostat calls for heat. Fan turns off according to plenum temperature.
- The L4064B,D,F,R and W have a manual fan switch which overrides the fan set points and keeps the fan running continuously.
- The L4064J and R have a special high temperature range suitable for gravity heating systems (gas, oil, coal, wood).
- Variety of fan and high limit setting ranges available.
- Standard wire push-in terminals and female receptacles are provided to speed installation.
- Rigid or swivel bracket mounting, or surface mounting.
- Suitable for line voltage, low voltage, or millivoltage control applications.
- Slotted wiring knockouts for easy installation.
- Strain relief bushings included with SUPER TRADELINE models protect wiring from field abuse.
- L4064 adapts to most competitive mounting holes for ease in replacement installations.
- SUPER TRADELINE models include deluxe case with mounting adapters for easy installation.

D.Y.
REV. 1-85●

Form Number 68-0024—1
©Honeywell Inc. 1985

FAN AND LIMIT CONTROLLERS



L4064A-F, J,R,T,W,Y

SPECIFICATIONS

IMPORTANT

THE SPECIFICATIONS GIVEN IN THIS PUBLICATION DO NOT INCLUDE NORMAL MANUFACTURING TOLERANCES. THEREFORE, THIS UNIT MAY NOT MATCH THE LISTED SPECIFICATIONS EXACTLY. ALSO, THIS PRODUCT IS TESTED AND CALIBRATED UNDER CLOSELY CONTROLLED CONDITIONS, AND SOME MINOR DIFFERENCES IN PERFORMANCE CAN BE EXPECTED IF THOSE CONDITIONS ARE CHANGED.

SUPER TRADELINE MODELS

SUPER TRADELINE models offer features not available on TRADELINE or standard models, and are designed to replace a wide range of Honeywell and competitive models. SUPER TRADELINE models are selected and packaged to provide ease of stocking and handling as well as maximum replacement value. Specifications for SUPER TRADELINE models are the same as those of standard models except as noted below.

SUPER TRADELINE MODEL AVAILABLE:

L4064B Fan and Limit Controller.

SUPER TRADELINE FEATURES INCLUDE:

- Universal adapters for 5/8, 3/4, and 1 in. diameter elements.
- Deluxe (large) case with cover.
- Wiring space for related controls.
- Mounting means—surface or rigid bracket.
- Two round wiring knockouts in top and 2 slotted in bottom of case.

- 857780AFC Stripped Wire (2) with 1/4 in. [6.4 mm] male flag connector attached.
- 110265A Rigid Bracket, single wiring with No. 8-32 setscrew.
- 127123 Steel Bushing with 135236 Wire Snap Ring to adapt insertion element to 1 in. [25.4 mm] hole in plenum.
- 137813 Strain Relief Bushing (2).
- Cross reference label and special instruction sheet.

TRADELINE MODELS

TRADELINE models offer features not available on standard models, and are designed to replace a wide range of Honeywell and competitive models. TRADELINE models are selected and packaged to provide ease of stocking and handling as well as maximum replacement value. Specifications for TRADELINE models are the same as those of standard models except as noted below.

TRADELINE FEATURES INCLUDE:

- Small case with cover.
- Wiring space for related controls.
- Two slotted wiring knockouts in bottom.
- 861503ANT female flag quick-connect terminals with 7 in. of No. 18 leadwire (2).

- 857780AFC male flag quick-connect terminal with 5 in. of No. 14 leadwire (2).
- Cross reference label, warning tag, and special instruction sheet.

ORDERING INFORMATION

WHEN PURCHASING REPLACEMENT AND MODERNIZATION PRODUCTS FROM YOUR TRADELINE WHOLESALE OR YOUR DISTRIBUTOR, REFER TO THE TRADELINE CATALOG OR PRICE SHEETS FOR COMPLETE ORDERING NUMBER, OR SPECIFY—

1. Order number.
2. Insertion depth—L4064A,B,E,F,J,R,T,W,Y only.
3. Adjustable high limit stop, if desired (include desired set point).
4. Accessories, if desired.

IF YOU HAVE ADDITIONAL QUESTIONS, NEED FURTHER INFORMATION, OR WOULD LIKE TO COMMENT ON OUR PRODUCTS OR SERVICES, PLEASE WRITE OR PHONE:

1. YOUR LOCAL HONEYWELL RESIDENTIAL DIVISION SALES OFFICE (CHECK WHITE PAGES OF PHONE DIRECTORY).
2. RESIDENTIAL DIVISION CUSTOMER SERVICE
HONEYWELL INC., 1885 DOUGLAS DRIVE NORTH
MINNEAPOLIS, MINNESOTA 55422-4386 (612)542-7500

IN CANADA—HONEYWELL LIMITED/HONEYWELL LIMITEE, 740 ELLESMERE ROAD, SCARBOROUGH, ONTARIO M1P 2V9. INTERNATIONAL SALES AND SERVICE OFFICES IN ALL PRINCIPAL CITIES OF THE WORLD.

STANDARD MODELS

MODELS: L4064A-F,J,R,T,W and Y Fan and Limit Controllers. See Tables I and II. Table I gives specifications in Fahrenheit degrees. Table II gives specifications in Celsius degrees.

TABLE I—L4064 SPECIFICATIONS IN DEGREES FAHRENHEIT.

MODEL	SENSING ELEMENT	MANUAL FAN SWITCH	SCALE RANGE	FAN-ON RANGE	FAN-OFF RANGE	HIGH LIMIT RANGE
L4064A	Helical bimetal	No	50 to 250	65 to 215	50 to 200	100 to 250
L4064B		Yes				
L4064C	Flat, spiral bimetal	No	250			
L4064D		Yes				
L4064E	Helical bimetal	No				
L4064F		Yes				
L4064J	Helical bimetal	No	80 to 350	100 to 305	80 to 290	150 to 350
L4064R		Yes				
L4064T	Helical bimetal	No	50 to 250	None—fan comes on 20 to 90 sec. after call for heat ^a	50 to 200	100 to 250
L4064W		Yes				
L4064Y		No				

^aTime will vary, depending on the voltage applied to the special fan switch heater and on the temperature surrounding the fan switch.

TABLE II—L4064 SPECIFICATIONS IN DEGREES CELSIUS.

MODEL	SENSING ELEMENT	MANUAL FAN SWITCH	SCALE RANGE	FAN-ON RANGE	FAN-OFF RANGE	HIGH LIMIT RANGE
L4064A	Helical bimetal	No	10 to 121	18 to 102	10 to 93	38 to 121
L4064B		Yes				
L4064C	Flat, spiral bimetal	No				
L4064D		Yes				
L4064E	Helical bimetal	No				
L4064F		Yes				
L4064J	Helical bimetal	No	27 to 177	38 to 152	27 to 143	66 to 177
L4064R		Yes				
L4064T	Helical bimetal	No	10 to 121	None—fan comes on 20 to 90 sec. after call for heat ^a	10 to 93	38 to 121
L4064W		Yes				
L4064Y		No				

^aTime will vary, depending on the voltage applied to the special fan switch heater and on the temperature surrounding the fan switch.

ELECTRICAL RATINGS (amperes):

	120 Vac		240 Vac		24 Vac		
	FAN	LIMIT	FAN	LIMIT	FAN	LIMIT	TIMER
Full Load	14	8	7	4	—	—	—
Locked Rotor	84	48	42	24	—	—	—
Max. Amp	—	—	—	—	—	2	.2

Pilot Duty—2 A at 25 Vac; 0.25 A at 0.25 to 12 Vdc.
 Maximum Combined Connected Load—2000 VA.
 L4064T—timer circuit 24 V, 0.085 A.
 HIGH LIMIT DIFFERENTIAL: 25 F [14 C].
 LIMIT STOP SETTING: 160 F to 250 F [72 C to 121 C] in 10 F [5.6 C] increments (specify when ordering).
 MINIMUM SWITCH OPERATING TEMPERATURE:
 L4064A-F,J,R—minus 40 F [minus 40 C].
 L4064T,W,Y—plus 50 F [10 C].
 MAXIMUM SWITCH OPERATING TEMPERATURE:
 L4064A-F,J,R—190 F [88 C].
 L4064T,W,Y—115 F [46 C].
 MAXIMUM ELEMENT TEMPERATURE:
 L4064A-F,T,W,Y—350 F [177 C].
 L4064J,R—250 F [121 C] above limit setting.
 MAXIMUM SURFACE MOUNTING TEMPERATURE:
 190 F [88 C].

MOUNTING DIMENSIONS: See Fig. 1.

MOUNTING MEANS:

L4064A,B,E,F,T,W,Y—rigid or swivel bracket or surface mounting.

L4064C,D—surface mounting only.

L4064J,R—rigid or swivel bracket mounting only.

ELEMENT DIMENSIONS:

L4064A,B,E,F,J,R,T,W,Y (helical)—3/4 in. [19.1 mm] diameter; 5, 8, or 11-1/2 in. [127, 203.2 or 292.1 mm] insertion.

L4064C,D (flat spiral)—1-1/2 in. [38.1 mm] diameter; 1-1/2 in. [38.1 mm] insertion.

ADJUSTMENT MEANS: Adjustable levers on scale-plate.

FINISH: Zinc-plated steel.

WIRING KNOCKOUTS:

L4064A-F,J,R—two in bottom of case, slotted for easy installation.

L4064T,W,Y—has two knockouts in bottom of case slotted for easy installation.

SUPER TRADELINE versions have two additional knockouts at the top of the case.

UNDERWRITERS LABORATORIES INC. APPROVALS:

L4064A,B,C,D,T LISTED—File MP466, Guide MBPR;
 L4064E,F,J,R,T,W and Y COMPONENT RECOGNIZED—File MP466, Guide MBPR2.

ACCESSORIES:

1. 110265A Rigid Bracket—single wing, with No. 8-32 setscrew.
2. 129250A Rigid Bracket—double wing, with No. 8-32 setscrew.
3. 32612A Swivel Bracket.
4. 137813 Strain Relief Bushing (2).
5. 857780AFC leadwires (2) with 1/4 in. [6.4 mm] male flag connectors attached.

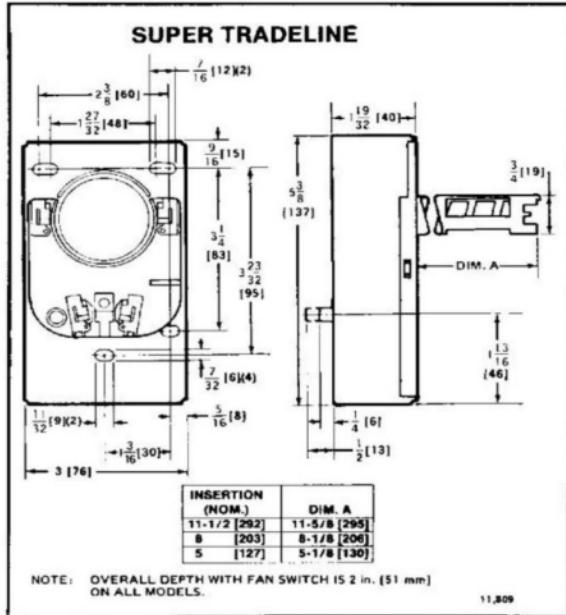

FIG. 1—MOUNTING DIMENSIONS IN in. [mm IN BRACKETS] OF SUPER TRADELINE MODEL.

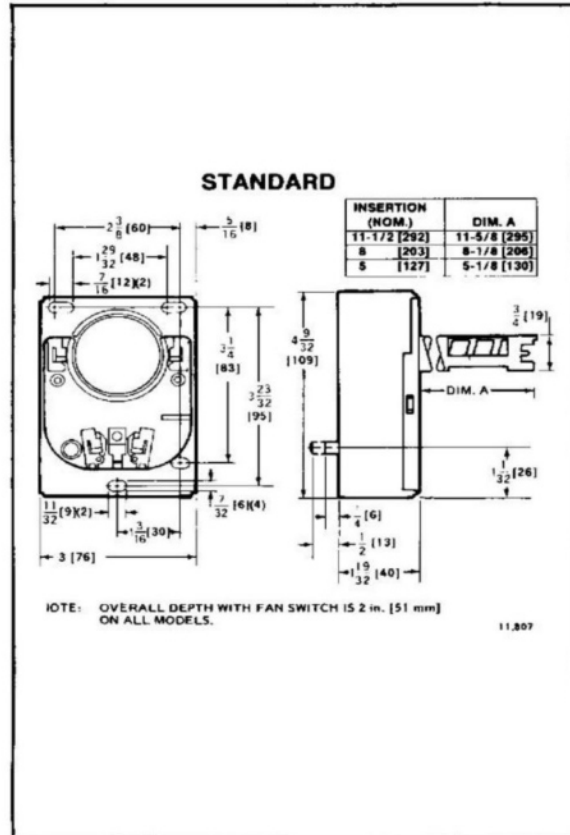

FIG. 2—MOUNTING DIMENSIONS IN in. [mm IN BRACKETS] OF STANDARD AND TRADELINE MODELS.

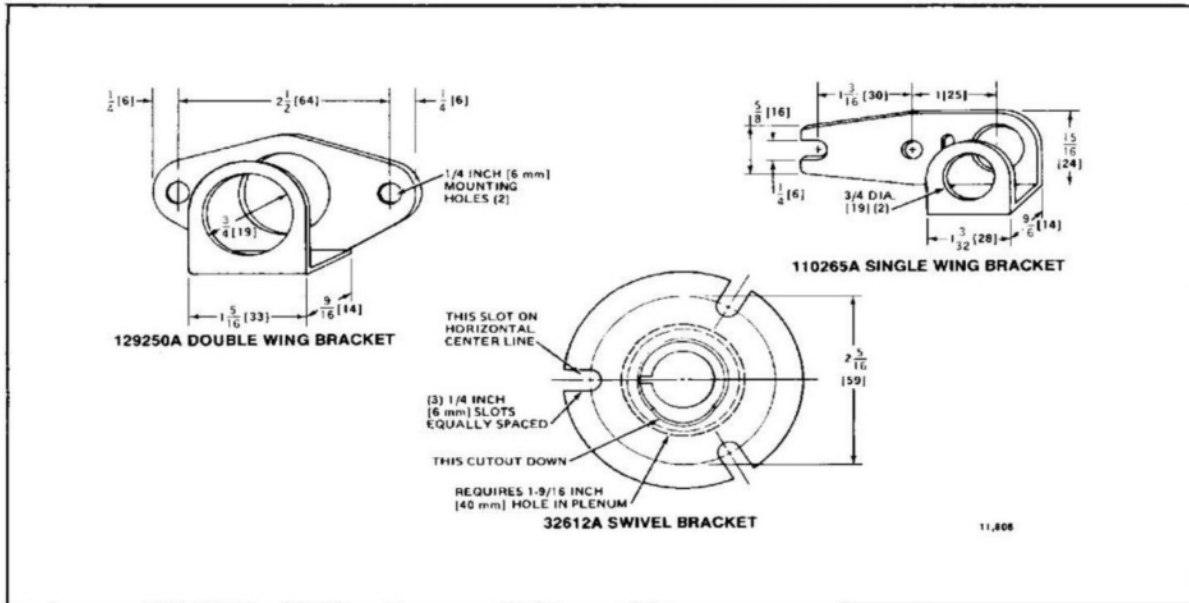

FIG. 3—MOUNTING DIMENSIONS IN in. [mm IN BRACKETS] OF BRACKETS.

INSTALLATION

WHEN INSTALLING THIS PRODUCT. . .

1. Read these instructions carefully. Failure to follow them could damage the product or cause a hazardous condition.
2. Check the ratings given in the instructions and on the product to make sure the product is suitable for your application.
3. Installer must be a trained, experienced service technician.
4. After installation is complete, check out product operation as provided in these instructions.

WARNING

Failure to remove brass jumper, if limit switch is in low voltage circuit, can cause electrical shock hazard or damage low voltage controls.

CAUTION

1. Disconnect power supply before beginning installation to prevent electrical shock or equipment damage.
2. When connecting cable or conduit to control, avoid straining the control case.

Follow furnace or burner manufacturer's instructions, if available. Do NOT exceed the ratings and limitations given in this section.

LOCATION

If this is a replacement installation, locate the L4064 in the same location as the control being replaced. Sensing tube length should be same as old control. If this is a new installation, the element should be installed only by a trained, experienced service technician according to the furnace manufacturer's instructions. The element must not touch any internal part of the furnace.

NOTE: The electrical rating is at maximum switch temperature of 190 F [88 C]. If plenum surface temperature exceeds 190 F [88 C], heat insulating material or mounting bracket must be used. The L4064J,R require the use of a bracket in gravity systems.

MOUNTING

The devices may be mounted as follows:

- L4064A,B,E,F,T,W,Y—surface mounting or bracket (rigid or swivel).
L4064C,D—surface mounting only.
L4064J,R—bracket (rigid or swivel) mounting only.

SURFACE MOUNTING

L4064A,B,E,F,T,W,Y

Hole in plenum should be just large enough to accommodate the 3/4 in. [19.1 mm] diameter element tube. For adequate clearance, a 13/16 in. [20.6 mm] diameter hole is recommended.

L4064C,D

Hole in plenum should be 1-9/16 in. [39.7 mm] diameter to accommodate the 1-1/2 in. [38.1 mm] diameter element.

ALL MODELS

1. Remove cover by squeezing sides and pulling off. Insert element in plenum and mark location of mounting holes. Make sure the case is snug against the plenum before marking the mounting holes.
2. Punch or drill holes for mounting screws.
3. Place insulation between plenum and case if necessary.
4. Fasten controller securely with mounting screws.

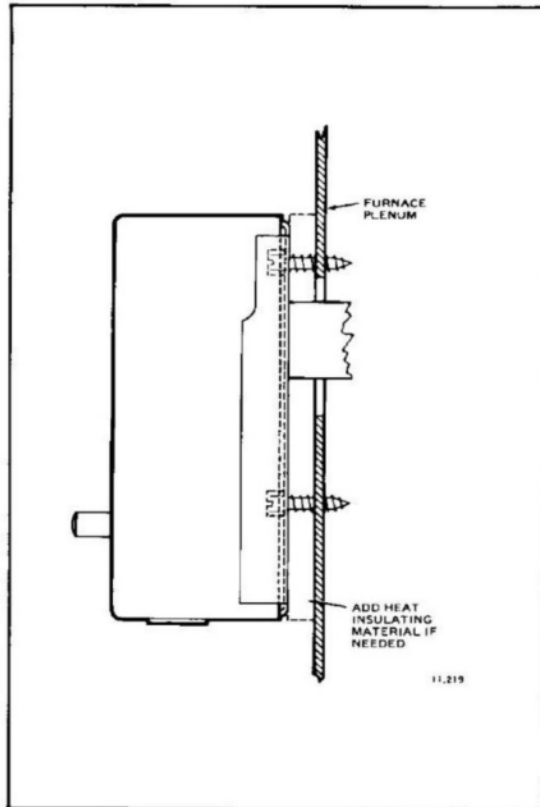

FIG. 4—SURFACE MOUNTING FOR L4064. THE L4064C AND D REQUIRE A 1-1/2 in. [38.1 mm] HOLE FOR ELEMENT INSERTION; ALL OTHER MODELS REQUIRE A 13/16 in. [20.6 mm] HOLE.

SWIVEL MOUNTING

L4064A,B,E,F,J,R,T,W,Y may be swivel-mounted. The swivel bracket requires a 1-9/16 in. [39.7 mm] hole in the plenum (Fig. 5).

1. Use bracket as a template to make the location of mounting holes in plenum. Drill or punch holes for mounting screws.
2. Fasten the bracket in place with furnished screws. Start the screws but do not tighten.
3. Insert element tube through bracket, straighten controller, and fasten. Tighten the mounting screws securely. It may be necessary to rotate the bracket to tighten all screws securely.

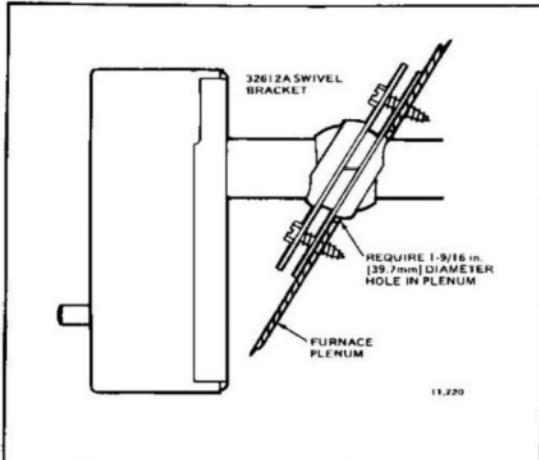

FIG. 5—SWIVEL MOUNTING. REQUIRES A 1-9/16 in. [39.7 mm] DIAMETER HOLE FOR ELEMENT INSERTION.

RIGID BRACKET MOUNTING

WARNING

When mounting control on bracket, setscrew **MUST** strike tube frame, **NOT** sensing element. If setscrew strikes sensing element, the safety limit function can fail and cause fire hazard.

L4064A,B,E,F,J,R,T,W,Y may be mounted using a rigid bracket. The rigid bracket requires a hole 13/16 in. [20.6 mm] diameter for element insertion (Fig. 6).

1. Use bracket as a template to mark the location of mounting holes in plenum. Drill or punch holes for mounting screws.
2. Fasten the bracket in place with furnished screws. Tighten the screws securely.
3. Insert element tube through bracket, straighten controller and fasten by tightening setscrew. Be sure screw strikes tube frame and does not strike coiled bimetal sensing element.
4. For replacement installations with existing 1 in. [25.4 mm] diameter hole. SUPER TRADELINE models are supplied with split steel bushings and wire snap ring. Follow the instructions below for using the steel bushing adapter.

STEEL BUSHING ADAPTER (SUPER TRADELINE models)

1. Insert one-half of the split steel bushing through the wire ring (Fig. 7). It may be necessary to spread the ring slightly.
2. Insert the other half of the steel bushing into the ring making sure tabs and ears are at the same ends.
3. Place bushing assembly on element, ear end first.
4. Holding bushing at seams, push firmly to the control end of element.
5. Insert element tube with adapter through bracket, straighten controller and fasten by tightening setscrew. Be sure screw strikes bushing and not coiled bimetal sensing element.

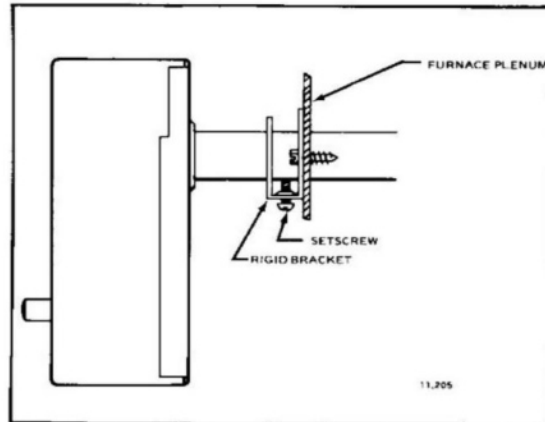

FIG. 6—RIGID BRACKET MOUNTING REQUIRES A HOLE 13/16 in. [20.6 mm] DIAMETER FOR ELEMENT INSERTION.

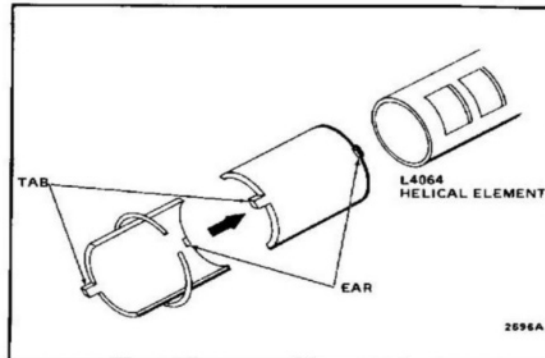

FIG. 7—USING SUPER TRADELINE ADAPTER.

WIRING

Disconnect power supply before beginning installation to prevent electrical shock or equipment damage.

All wiring must comply with local electrical codes and ordinances or in the absence of local codes with the National Electrical Code ANSI C1-1981—NFPA 70. Follow burner or furnace manufacturer's instructions if available; otherwise, see Figs. 12 and 13 and proceed as follows.

IMPORTANT

The brass jumper is the breakaway type. It must be removed when the limit is used in the low voltage circuit. To remove jumper, break with a needlenose plier and remove completely. Once removed, it is not replaceable. See Fig. 11 for location.

The slotted knockouts on the bottom of the case and the strain relief bushing (supplied with SUPER TRADELINE models) are provided to simplify the installation procedure and to protect the wires.

1. To remove the slotted knockout(s), use a needlenose pliers as shown in Fig. 8 and pull straight down.

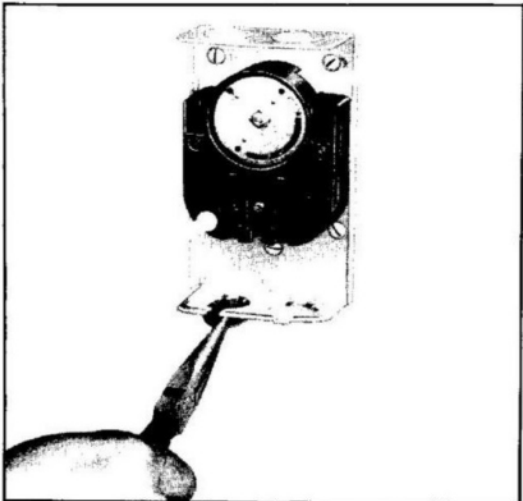

FIG. 8—REMOVING SLOTTED KNOCKOUTS FROM SUPER TRADELINE MODELS.

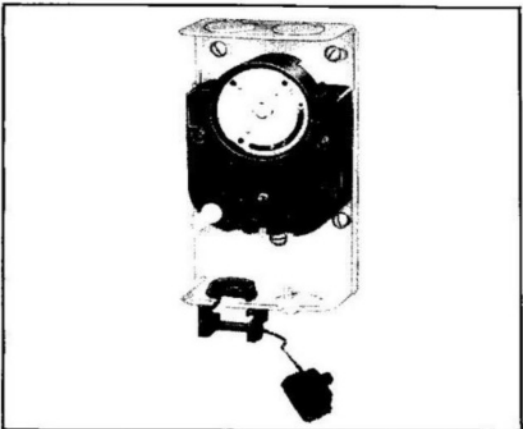

FIG. 9—INSERT STRAIN RELIEF BUSHING.

2. If cable is used, we recommend using a strain relief bushing in the knockout (Fig. 9). Bushing is available from your local electrical supply. The open side of the bushing should face the open side of the knockout.

3. Refer to the following section for types of wiring connections (standard wire push-in terminals or female receptacle).

4. If strain relief bushing is used, close the movable gate when all wires have been connected to the terminals (Fig. 10).

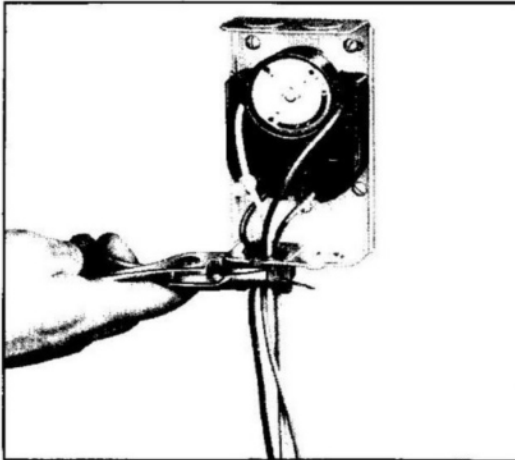

FIG. 10—CLOSING THE STRAIN RELIEF BUSHING.

WIRING CONNECTIONS

When connecting cable or conduit to this controller, use care to avoid strain on the control case. Connections can be made to standard wire push-in terminals or female receptacles for 1/4 in. [4.6 mm] male flag connectors on both the fan and limit switches (Fig. 11). L4064T,W,Y has male push-in terminal for low voltage heater, which requires a 1/4 in. [4.6 mm] female flag connector.

FOR STANDARD WIRE PUSH-IN TERMINALS

Connect wires to the terminals as follows:

1. Use Nos. 14, 16, or 18 solid wire or Nos. 14 or 16 stranded wire, depending on electrical requirement.
2. Strip insulation from wires the distance shown by the strip gauge on the controller. If wire insulation is 4/64 in. [2 mm] thick, strip additional 1/4 in. [6 mm] to ensure wire seats securely in push-in connectors.
3. Solid wire may be inserted directly into the terminal holes. If stranded wire is used, insert a small screwdriver into the slot next to the terminal. Push screwdriver in and hold while inserting wire into terminal (Fig. 11). Remove screwdriver. If stranded wire is solder-dipped, it can be pushed directly into terminal holes.

FOR FEMALE RECEPTACLES

It is recommended that the female receptacles be used for wiring accessory equipment; i.e., electronic air cleaner, humidifier, etc.).

Connect wires to the receptacles as follows:

1. Use Nos. 14 to 18 size wire, depending on electrical requirement.
2. Attach 1/4 in. [4.6 mm] male flag connector to each wire. Two 1/4 in. male flag connectors with leadwires are supplied with TRADELINE and SUPER TRADELINE models.

3. Push male flag connector directly into the female receptacle. Make sure that the flag is forced to the bottom of cavity and wire is in the channel (Fig. 11).

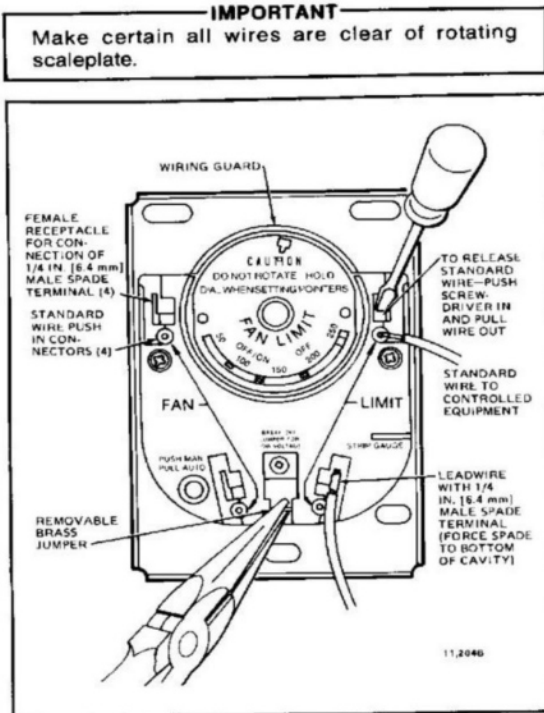

FIG. 11—LOCATION OF WIRING CONNECTIONS.

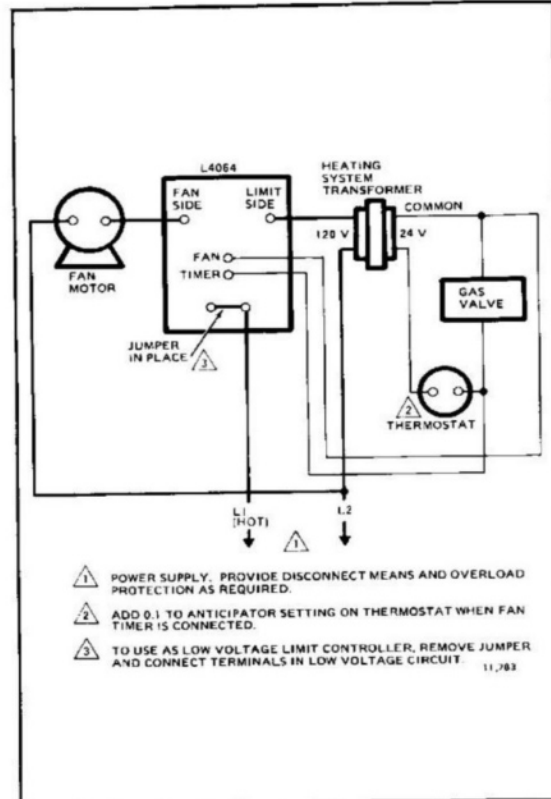

FIG. 12—L4064T, W, Y 3-WIRE LINE VOLTAGE HOOKUP.

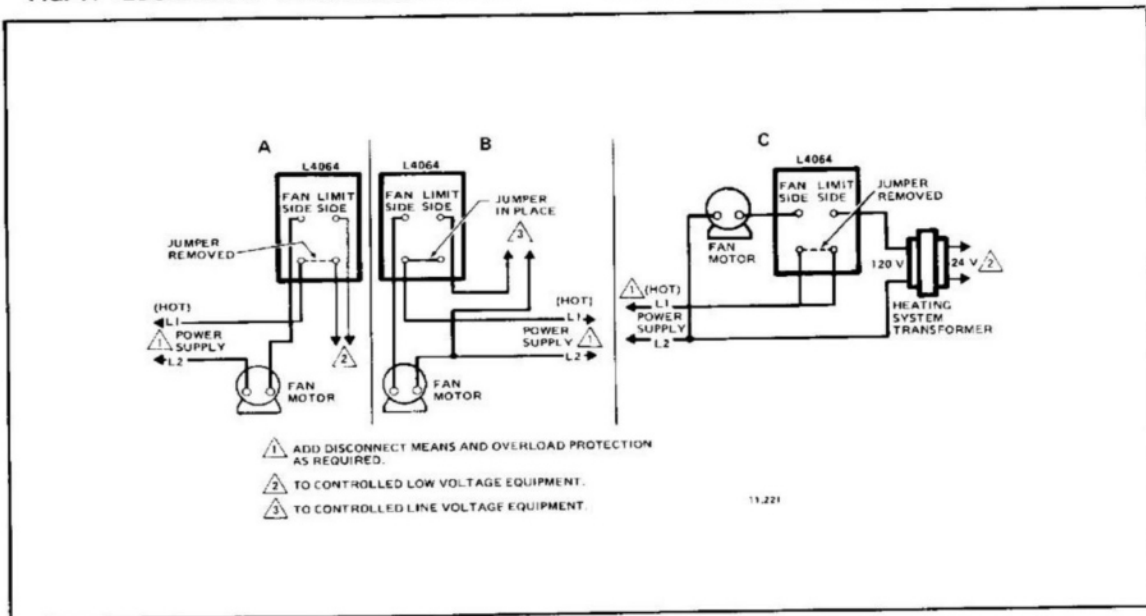

FIG. 13—A: LIMIT IN LOW VOLTAGE CIRCUIT.
 B: LIMIT IN LINE VOLTAGE CIRCUIT.
 C: LIMIT IN LINE VOLTAGE CIRCUIT WITHOUT JUMPER.

SETTINGS AND ADJUSTMENTS

CAUTION

When adjusting the fan and limit set point lever (Fig. 14), hold the scaleplate dial to keep it from turning and straining the sensing element.

IMPORTANT

The L4064T,W,Y use a bimetal heater, in the fan switch, to turn on the fan 20 to 90 seconds* after a call for heat. When the call for heat ends, the fan will continue to run until the fan-off temperature is reached and the bimetal heater switch cools down (2 to 4 minutes). If the L4064T,W or Y is used to replace an L4064A or B, the blower fan may circulate cool air until the plenum heats up. No adjustment of the fan-on time is possible.

Move each set point lever to the control point recommended by the burner or furnace manufacturer. Use gentle finger pressure.

FAN SETTING ADJUSTMENT

1. Move the FAN OFF lever to the temperature at which the fan is to stop to prevent circulation of cool air.

2. Move the FAN ON lever as follows:

L4064A-F—FAN ON range is from 15 F [8.3 C] above the FAN OFF setting to 35 F [19.4 C] below the LIMIT OFF setting.

L4064J,R—FAN ON range is from 20 F [11.1 C] above the FAN OFF setting to 45 F [24.9 C] below the LIMIT OFF setting.

L4064T,W,Y—Move the FAN ON lever as needed for setting the FAN OFF indicator and LIMIT indicator. The FAN ON indicator is nonfunctional on the L4064T; a special bimetal heater acts to turn on the fan 20 to 90 seconds* after a call for heat from the thermostat. On-time will vary, depending on the voltage applied to the bimetal heater and on the temperature surrounding the fan switch.

With connected bimetal heater, fan-off settings will be determined according to Tables III and IV. If not connected, then operation is the same as all other devices.

TABLE III
L4064T,W,Y FAN-ON TIME FROM A COLD START (IN SECONDS)

AMBIENT TEMP. °F	HEATER WRAPPED BIMETAL FAN SWITCH APPLIED VOLTAGE								
	23.0 V			24.0 V			27.6 V		
	Min.	Ave.	Max.	Min.	Ave.	Max.	Min.	Ave.	Max.
50	50	80	120	40	60	90	20	30	40
72	40	60	100	30	50	80	15	25	35
115	30	50	80	20	40	70	10	20	30

NOTE:

- "Fan-off" lever is set at 120° F.
- Lower "fan off" settings will increase "fan-on" timings.

TABLE IV
L4064T,W,Y FAN OFF TIME (SECONDS)

AMBIENT TEMP. °F	HEATER WRAPPED BIMETAL FAN SWITCH APPLIED VOLTAGE								
	23.0 V			24.0 V			27.6 V		
	Min.	Ave.	Max.	Min.	Ave.	Max.	Min.	Ave.	Max.
50	45	75	120	50	90	140	85	130	190
72	55	120	200	60	120	220	90	165	260
115	60	140	235	85	165	270	110	200	280

NOTE:

- The "fan-off" lever is set at 120° F. (Lower setting will decrease fan off time, higher setting will increase fan off time.)
- The bimetal heater is energized once for 15 minutes.
- The fan will keep running until the bimetal timing mechanism (built-in) cools down to below 115° F and the L4064T,W,Y primary sensor temperature drops below the fan off set point. Table IV represents bench test timings where the entire L4064 is at the indicated ambient temperature.

MANUAL FAN SWITCH (L4064B,D,F,R,W)

For constant fan operation (overriding fan setting levers), push the FAN switch button in. For fan to cycle automatically, pull button out.

LIMIT SETTING ADJUSTMENT

These controls have a limit stop which prevents the limit indicator lever from being adjusted beyond the equipment manufacturer's specifications.

1. Push a stiff wire through hole in scaleplate to depress the stop disc not more than 1/16 in. [1.6 mm] to release stop lock (Fig. 14). Stop disc is on back of scaleplate.

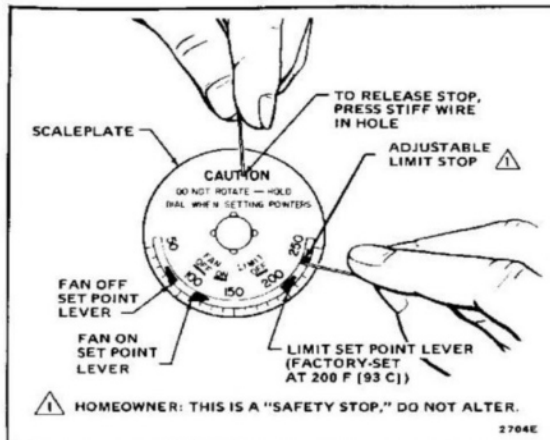



FIG. 14—CHANGING THE HIGH LIMIT STOP.

2. When depressing the stop disc, insert another stiff wire next to limit stop (Fig. 14) and use this wire to move stop to desired setting. If the L4064 is a replacement control, the high limit stop setting should be the same as that of the control being replaced. (Move stop clockwise  to lower the setting, counterclockwise  to raise it.) Then remove both wires.

3. Set the LIMIT OFF lever to the temperature at which the high limit switch is to open to stop the burner. If the high limit stop has been properly set, the LIMIT OFF lever should be as high as the stop permits.

*The fan on timing can vary depending on applied voltage and switch ambient.

OPERATION

L4064A-F,J,R—As the plenum temperature rises, the coiled, bimetal sensing element of the control warps and mechanically makes the fan contacts (at the FAN ON temperature setting). During normal operation, the call for heat ends before the LIMIT setting is reached and the fan contacts break as the plenum temperature falls and the FAN OFF setting is reached.

If the call for heat continues until the temperature in the plenum rises to the LIMIT setting, the bimetal element will mechanically break the limit contacts and de-energize the heating control circuit.

L4064T,W,Y—The operation of the L4064T,W,Y are the same except that the controller uses a bimetal heater in the fan switch to make the switch contacts independent of the bimetal sensing element. This heater acts to anticipate the rise in plenum temperature and turns on the fan 20 to 90 seconds* after the thermostat calls for heat. Actual on-time will vary, depending on the voltage applied to the bimetal heater and on the temperature surrounding the fan switch.

*The fan on timing can vary depending on applied voltage and switch ambient.

CHECKOUT

When installation is complete, disconnect the fan motor circuit at the L4064. Turn on power and set thermostat to call for heat. Burner should come on and limit controller should shut burner off when plenum temperature reaches the limit set point. Turn off power, reconnect the fan switch, turn on power and again set thermostat to call for heat. On L4064A-F,J,R fan should start when plenum temperature has reached fan-on

setting. On L4064T,W,Y, fan should start 20 to 90 seconds after a call for heat. Fan should shut off on all L4064 models (except L4064T,W,Y) when call for heat ends and plenum has cooled to fan-off setting. The L4064T,W,Y shut off the fan when the sensing element and the bimetal heater have cooled to the fan-off setting. This is usually 2 to 4 minutes after the call for heat ends.