



Bay 2000C Fireplace Insert & Freestanding Stove

Installation, Operation and Maintenance Instructions



Fireplace Inserts

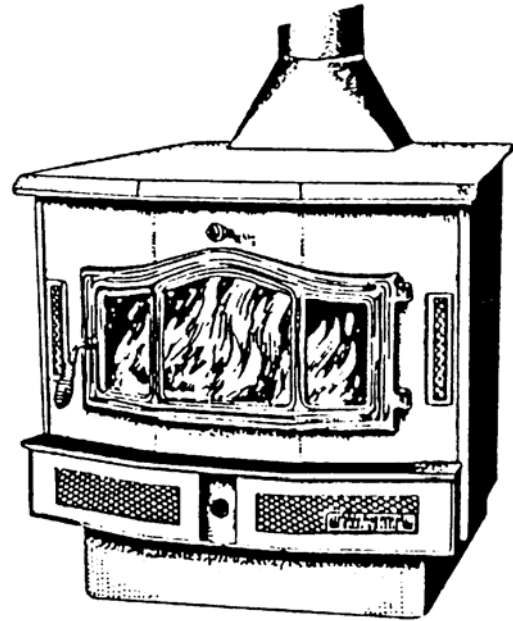

Freestanding Stoves

Safety and emissions tested at Intertek Testing Services, Middleton, Wisconsin, to the appropriate standards for the U.S. – to UL 127 for inserts and UL 1482 for freestanding models.

RJM Manufacturing, Inc.
PO Box 27 ♦ 1875 Olson Drive
Chippewa Falls, WI 54729
(715) 720-1794 ♦ Fax (715) 720-1797

Congratulations on your purchase of an Energy King solid fuel appliance. Your stove or insert is designed for a lifetime of durable, reliable performance and easy operation.

This manual describes the installation and operation of the Energy King Bay 2000C freestanding stove and fireplace insert models. These heaters are tested to EPA Certification for emissions.

If this stove is not properly installed, a house fire may result. For your safety, follow the installation directions. Contact local building or fire officials about restrictions and installation inspection requirements in your area. You will also need to determine if you are required to obtain a permit from the local governing authority.

Please read this entire manual before you install and use your new stove. Failure to follow instructions may result in property damage, bodily injury, or even death.

Please keep this manual in a safe place for future reference.

Table of Contents

SAFETY NOTES – IMPORTANT	1
COMPONENTS	2
INSTALLATION MATERIALS NEEDED FOR YOUR SAFETY	3
FLOOR PROTECTOR.....	3
FIREPLACE INSERT INSTALLATION.....	3
SPECIFICATIONS – MODEL BAY 2000C.....	3
CLEARANCES TO COMBUSTIBLES	4
VENTING SYSTEM.....	5
CONNECTION TO A MASONRY FIREPLACE	6
BEFORE INSTALLATION.....	6
MOUNT TRIM PANELS	7
BRASS TRIM	7
DIRECT CONNECT	7

FREESTANDING STOVE INSTALLATION	8
SPECIFICATIONS – MODEL BAY 2000C.....	8
BASE ASSEMBLY	9
FLUE ADAPTOR	9
CLEARANCES TO COMBUSTIBLES	10
FLOOR PROTECTOR	10
VENTING SYSTEM.....	11
CHIMNEY CONNECTOR.....	11
FIRESTOPPING.....	13
THIMBLE.....	14
BRICK CHIMNEY THIMBLE ASSEMBLY.....	15
WARNINGS.....	18
DO NOT BURN.....	18
BACKPUFFING.....	18
OVERFIRE	18
OPERATING YOUR ENERGY KING.....	19
WHAT IS A CATALYTIC WOODSTOVE?	19
USING YOUR CATALYTIC WOODSTOVE	19
TROUBLESHOOTING YOUR CATALYTIC COMBUSTOR.....	20
REPLACING YOUR CATALYTIC COMBUSTOR	21
BURNING YOUR ENERGY KING STOVE	22
OPERATING THE CIRCULATING BLOWER.....	23
WOOD.....	24
MAINTAINING YOUR ENERGY KING	24
DISPOSAL OF ASHES.....	24
CREOSOTE – FORMATION AND NEED FOR REMOVAL.....	25
CARE OF GLASS	25
CARE OF BRASS DOORS.....	25
CARE OF BLOWER	25
GASKET REPLACEMENT	26
TROUBLESHOOTING GUIDE.....	27
UNIT DOES NOT BURN PROPERLY	27
UNIT DOES NOT GIVE OFF ENOUGH HEAT.....	27
UNIT IS MAKING NOISE/DISTRIBUTION BLOWER IS VIBRATING.....	28
BLOWER IS NOT WORKING.....	28
USE AND MAINTENANCE OF A CATALYST	29
FREQUENTLY ASKED QUESTIONS.....	30

SAFETY NOTES – IMPORTANT

1. Never use gasoline or similar liquids to start or “freshen” a fire. Keep all such liquids away from your stove or insert.
2. Watch your unit closely during operation. If any part starts to glow red or white, it is in an overfire condition. Close the air controls completely until the glowing has stopped.
3. Your unit is hot while in operation. Keep children, clothing and furniture away. Contact may cause skin burns.
4. Never burn wet or green wood. Store all wood in a dry location, away from the elements.
5. Never burn garbage. This will damage the catalytic combustor.
6. If processed, solid fuel firelogs are used, do not poke or stir logs while they are burning. Use only firelogs that have been evaluated for the application in the fireplace and refer to firelog warnings and caution markings on packaging prior to use.
7. Do not let an accumulation of either soot or creosote build up in your chimney or inside the firebox.
8. Check your chimney system carefully before installation. If in doubt about its condition, contact a professional.
9. All fuel burning appliances require proper combustion air to operate and to avoid negative air pressure in your home. Negative air pressure will cause safety and operation problems.
10. Do not connect your solid fuel appliance to a chimney flue already venting another appliance.
11. Dispose of cool ashes with care. They should be stored in a non-combustible, metal container. Please read and follow all the instructions on page 24 of this manual for proper storage and disposal of ashes.
12. Comply with all minimum clearances to combustibles as they appear in this manual.
13. Consult your local building codes before installation.
14. Build the fire directly on the firebrick. Do not elevate the fire by using rates or andirons.
15. You will need to cure the painted surfaces of your Energy King. For the first few fires, adjust the air control to a medium fire after ignition. This will allow the paint to cure in an even manner. (There may be small amounts of paint fumes on initial fires.)
16. Start your fire with paper and kindling. Adding of fuel should be moderate as the fire progresses. Do not burn large quantities of paper or foreign materials that create an extremely hot, quick fire.
17. The fuel loading door and ash pan must remain closed during operation. When reloading your stove, always open the air controls and the bypass, and wait a short period of time before opening the doors.
18. For further information on using your woodstove, obtain a copy of the National Fire Protection Association’s, “Using Coal and Woodstoves Safely,” NFPA No. NS-10-1978. The address of the NFPA is 1 Batterymarch Park, P. O. Box 9101, Quincy, MA 02269-9101.

Components

Familiarize yourself with the components of your stove before installation and operation. This owner's manual has been designed to assist you in installing, operating and maintaining your Energy King stove efficiently and safely. Keep it in a safe place for future reference.

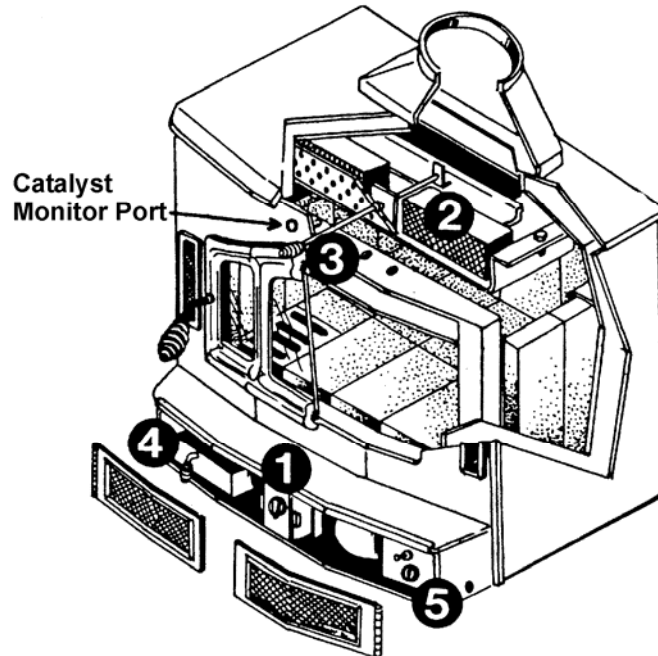

1. **Manual Draft Control.** Controls burn rate by regulating air entering the stove. It is located beneath the loading door. Turn the control all the way to the right for maximum air intake, burn rate and heat output, and all the way to the left for minimum air intake and heat output, with a low burn rate.
2. **Catalytic Combustors.** The wood heaters contain catalytic combustors, which need periodic inspection and replacement for proper operation. It is against the law to operate these stoves in a manner inconsistent with operating instructions in this manual or if the catalytic element is deactivated or removed. The catalytic combustors in these stoves are designed to burn the smoke, carbon monoxide and particulate, which are not burned by the fire. Once the fire has been established you can engage the catalytic combustors by shutting the bypass. (Minimum catalytic light off will not occur until the stove reaches 500 degrees F.) (See the instructions on page 21 for replacement of the catalytic combustors.)
3. **Bypass.** The bypass control is located above the loading door. The bypass control should be pulled out all the way to allow smoke to bypass the catalytic combustor when first starting a fire and until the unit reaches the 500-degree temperature necessary for light off. The catalytic bypass should also be pulled out all the way when loading the stove with fuel.
4. **Ash Pan.** Designed for easy clean up of ash accumulation. Do not operate the stove with the ash pan open, always keep it closed.
5. **Blower.** The blower is designed to provide additional heating value and forced air convection. Three speeds allow easy adjustment.

Installation Materials Needed for Your Safety (Freestanding Stoves)

Chimney Connector. Also known as flue pipe or stovepipe, the chimney connector joins the stove to the chimney. It should be 6 inch diameter, minimum 24 MSG black or 25 MSG blued steel.

Thimble. A manufactured or site-constructed device installed in combustible walls and ceilings through which the chimney connector passes to the chimney. It is intended to keep walls from igniting.

Chimney. You must use either an approved masonry chimney or a prefabricated 6-inch listed high temperature (tested to 2100 degrees F.) residential and building type heating appliance chimney per UL 103 or ULC S629. The chimney size should not be less than or more than three times greater than the cross-sectional area of the flue collar. Components required by manufacturers for installation such as the chimney support base, firestop (as appropriate), attic insulation shield, insulated tee, etc., are necessary to assure a safe chimney installation. Use only components manufactured for the chimney.

Floor Protector

Stove. Use a listed floor protector or any non-combustible material.

Insert. Use a listed floor protector or material having a thermo conductivity of K-O.84 BTU – inches per foot square – hour – Fahrenheit degrees; or equivalent to 3/8" non-asbestos millboard.

Fireplace Insert Installation

Specifications – Model Bay 2000C

Height	23 ¾"
Width	33"
Depth	24"
Weight	460 lbs.
Maximum Log Size	21"

Minimum Fireplace Dimensions

Height	23 ¾"
Width	32"
Depth	16"

Surround Dimensions

Height	32"	Width	45"
--------	-----	-------	-----

Heating Capacity

Low Burn Rate	11,400 BTU/Hr.
High Burn Rate	34,600 BTU/Hr.

Weighted Average Particulate Emissions
2.5 grams per hour

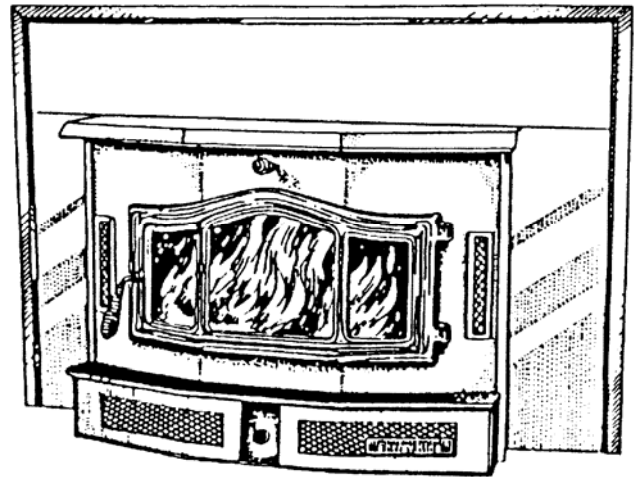

Overall Efficiency 78.5%

Efficiency calculated per CSA B415 Standard

(Unit was tested with blower, three-speed switch)

Clearances to Combustibles

Model Bay 2000C Fireplace Insert

A	To Mantle	18"
B	To Side Trim	9"
C	To Top Trim	14"
D	To Sidewall	16"
E	Hearth Pad Extension to front	16"
F	Hearth Pad Extension to Side	8"

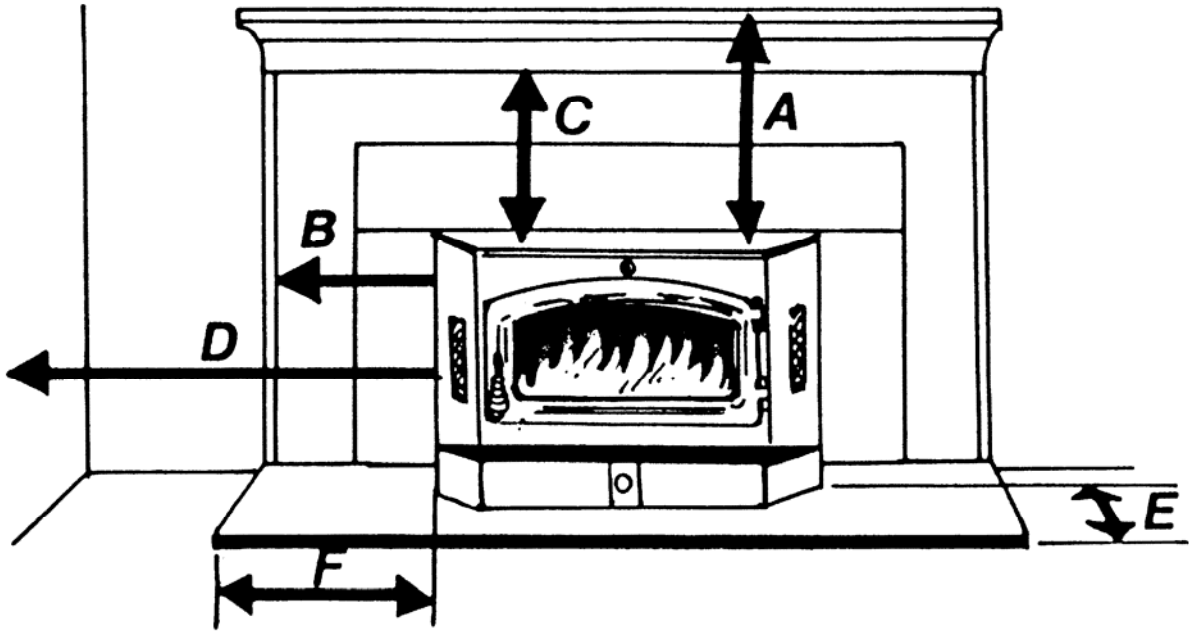

Refer to NFPA 211 for clearance reduction methods.

Venting System

Proper draft must be provided for your Energy King unit. Draft is the force that moves air from the stove up through the chimney. The amount of draft in your chimney depends on the length of the chimney, local geography, nearby obstructions, and other factors. Too little draft may cause backpuffing into the room and plugging of the chimney or catalyst.

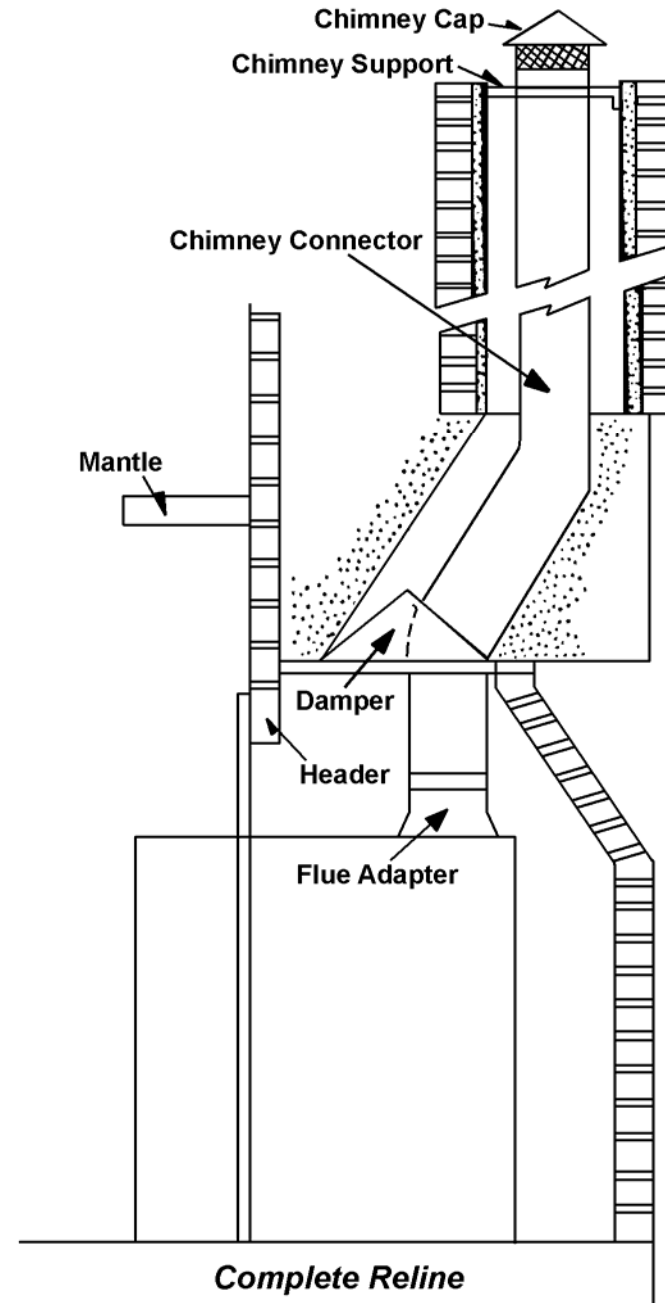

The Energy King fireplace insert model Bay 2000C is intended only for installation into a masonry fireplace constructed in accordance with the requirements of the Standard for Chimneys, Fireplaces, Vents and Solid Fuel Burning Appliances, NFPA No. 211, or applicable local code requirements. Please consult local building and fire officials about fire restrictions and installation requirements. **FOR USE WITH SOLID FUEL ONLY.**

Connection to a Masonry Fireplace

There are several kits available to connect the stove to a masonry fireplace. Look for a listed kit. The kit is an adapter that is installed at the location of the fireplace damper. The existing damper may have to be removed to allow installation of the kit. The key points of this type of stove connection are, first, the connector pipe must extend up the chimney above where the fire clay liner starts. Secondly, the areas of the kit installation and connector penetration should fit tightly and be sealed with high temperature furnace cement unless the kit's instructions state otherwise.

The tight fitting installation aids the proper draw of the chimney.

DO NOT REMOVE BRICKS OR MORTAR FROM MASONRY FIREPLACE. INSTALL AND USE ONLY IN MASONRY FIREPLACE. USE A LISTED FLOOR PROTECTOR OR ANY NON-COMBUSTIBLE MATERIAL. FIREPLACE INSERT FLOOR PROTECTOR MUST EXTEND AT LEAST 8 INCHES TO EACH SIDE OF UNIT AND 16 INCHES IN FRONT.

The Bay 2000C will insert into any masonry fireplace that is at least (A) 32" wide, (B) 24" high, and (C) 16" deep.

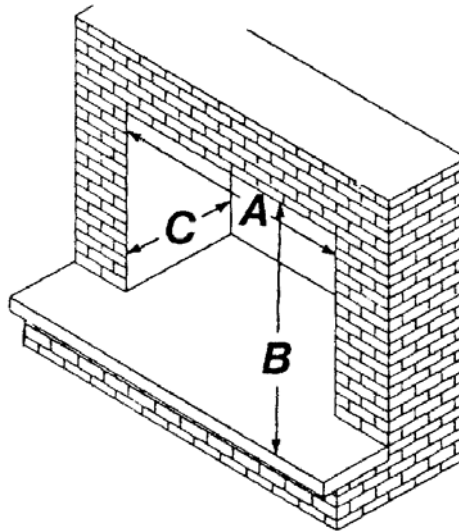

Before Installation

1. Check to make sure your masonry fireplace and chimney are in safe condition. Check the chimney for cracks, loose mortar, and other signs of deterioration and blockage. The insert should not be installed until it is determined that the chimney is safe for use. Since an oversized flue contributes to the accumulation of creosote, the size of the flue should be checked to determine that it is not too large for the insert.

The fireplace must be constructed to meet UBC Chapter 37 standards.

2. Clean the fireplace thoroughly.
3. Remove damper plate or block into open position with a non-combustible material.
4. Flue and chimney should be cleaned before installation.

Mount Trim Panels

5. Measure from back of the unit to the front and mark on the sides the location of the support angle.
6. Place the angle on the side of the unit and mark the holes for the locking screws. Drill three 3/16" holes and bolt in place on both sides of the unit.
7. Bolt side trim panels to the support angle with screws and tinnerman nuts.
8. Mount top panel to side panel.

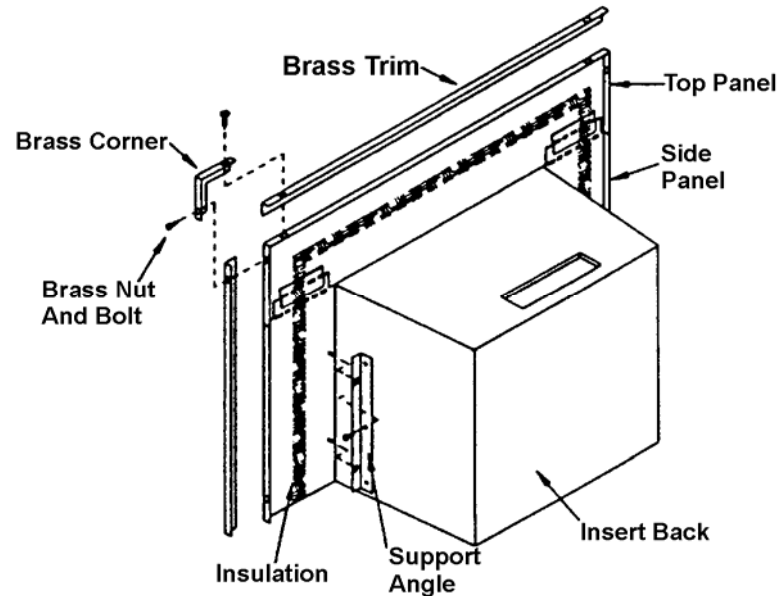

Brass Trim

9. Place side brass pieces on the side of the trim panels and cut to length.
10. Place top brass piece on top trim panel and cut to length.
11. Place brass corner piece over the side and top pieces. Mark and drill two 3/16" holes through brass.
12. Drill one 3/16" hole near the bottom of each side brass piece.
13. Using six brass bolts and nuts, bolt brass trim to trim panels.
14. Place insulation around trim panels. Slide insert into masonry fireplace. Be sure to center and level unit in place. Push tight against fireplace front. Make sure unit is in far enough to allow proper chimney hookup, and smoke outlet is behind fireplace lintel to assure safe operation. If brick is rough, additional insulation may be needed. Use only HIGH HEAT insulation approved for woodburning stoves and inserts.

Direct Connect

The 8" obround connection (cast iron) must be bolted securely to the fireplace and fastened to the chimney liner. A 6" offset direct connection must be used when the installation utilizes a 6" flexible stainless liner.

Freestanding Stove Installation

The Bay 2000C Freestanding Stove must be connected to a listed high temperature (2100 degrees F) residential type and building heating appliance chimney per US 103 or ULC S629 or an approved masonry chimney with a flue liner.

Specifications – Model Bay 2000C

Height	35"
Width	33"
Depth	24"
Weight	510 lbs.
Maximum Log Size	21"

Heating Capacity

Low Burn Rate	11,400 BTU/Hr.
High Burn Rate	34,600 BTU/Hr.

Efficiency

Weighted Average Particulate Emissions
2.5 grams per hour

Overall Efficiency 78.5%
Efficiency calculated per C.S.A. B 415 Standard

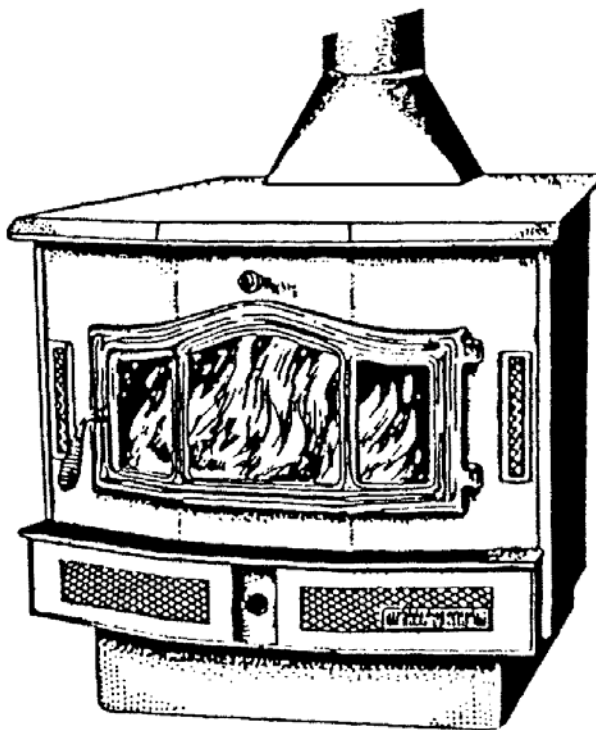

(Unit was tested with blower, three-speed switch.)

Base Assembly

To assemble as a stove, you need to bolt the base to the bottom of the unit using five ¼" self-tapping screws.

Remove door, brick and grate. Set unit on its back to mount the base. Place base with slotted holes towards the unit and line up with punched holes on the bottom of the unit. Use the five ¼" self-tapping bolts to mount securely.

Flue Adaptor

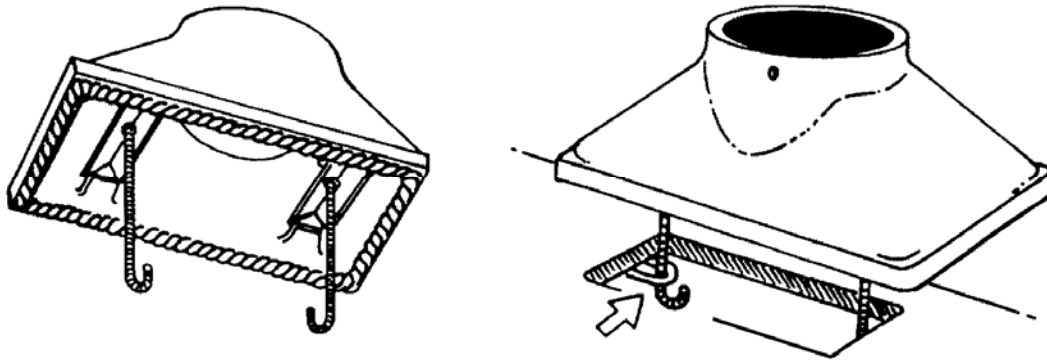

The flue adaptor must be secured atop the unit for freestanding stove installation.

To attach the adaptor:

1. Attach the flat gasket to the adapter.
2. Set the flue adaptor onto the top of the flue opening.
3. Center the adapter evenly over the flue.
4. Locate the two J shaped threaded screws. Remove the nut and washer from each. Set them aside.
5. Lower the J shaped screws into the flue adapter opening, and insert each through the holes in the adapter and stove.
6. Reaching inside the flue adapter, replace the nut and washer on each J shaped screw.
7. Tighten securely, using a wrench.

Clearances to Combustibles

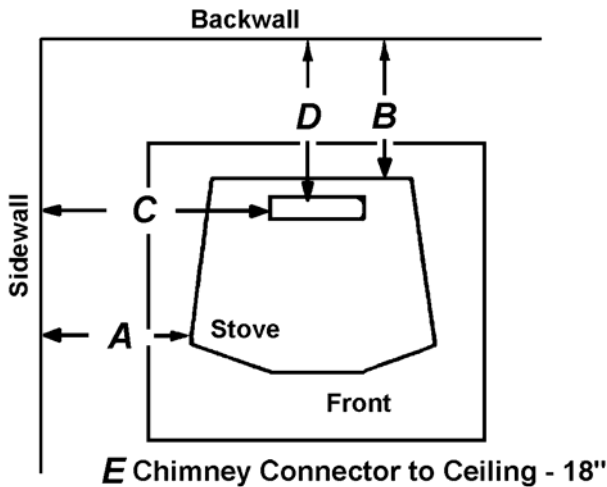

Model Bay 2000C Freestanding Stove

A	Unit to Sidewall	16"
B	Unit to Backwall	18"
C	Chimney Connector to Sidewall	29"
D	Chimney Connector to Backwall	18"
E	Chimney Connector to Ceiling	18"

When locating your stove, consider safety, convenience, traffic flow, and the fact that the stove will need a chimney and chimney connector.

Your stove should be located away from doors and hallways and in an open area to allow for necessary clearances.

Keep furniture, drapes, curtains, wood, paper, and other combustibles far away from the stove.

Never install the stove in locations where gasoline, kerosene, charcoal lighter, or any other flammable liquids are used or store.

DO NOT INSTALL THIS STOVE IN A MOBILE HOME.

A variety of prefabricated clearance reduction systems may be available through your stove dealer. Always look for a safety listing label on the product when selecting a prefabricated clearance reduction system and make sure it is designed for use with a woodstove. Follow exactly the installation instructions provided with this system. Refer to NFPA 211 for clearance reduction methods.

Floor Protector

The stove must be placed on a floor protector if the floor is wood or other combustible flooring. IF CARPETING IS PRESENT, IT MUST BE REMOVED. THE FLOOR PROTECTOR MUST NOT BE PLACED ON CARPET. The floor protector must extend at least 8 inches from the sides and back of the stove, and 16 inches from the door of the stove. Insulate this area with 3/8" millboard or equivalent (R Factor = .75) The overall base size is 50" x 50" minimum.

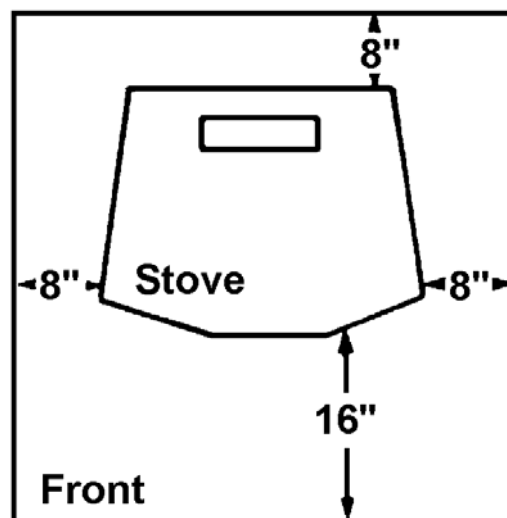

Venting System

A chimney connector and chimney make up the venting system. Inside, chimney temperatures may exceed 2000 degrees F. To protect against a chimney fire, the connector and chimney must be properly installed and maintained. When a connection is made through a combustible wall to the chimney, a thimble must be used. A chimney support package must be used when a connection is made through the ceiling to a prefabricated chimney. These accessories are of primary importance to provide safe clearances to combustible wall and ceiling materials.

The unit may be connected to either a code approved masonry chimney with a flue liner or a prefabricated listed high temperature (tested to 2100 degrees F) residential and building type heating appliance chimney per UL 103 or ULC S629. The chimney size should not be less than or more than three times greater than the cross-sectional area of the flue collar. *Do not connect it to a chimney serving another appliance.*

Proper draft must be provided for your Energy King unit. Draft is the force that moves air from the stove up through the chimney. The amount of draft in your chimney depends on the length of the chimney, local geography, nearby obstructions, and other factors. Too much draft may cause excessive temperatures in the stove and may damage the catalytic combustor. Inadequate draft may cause backpuffing into the room and plugging of the chimney or catalyst.

Chimney Connector

Your chimney connector should be 6-inch diameter, minimum 24 MSG black or 25 MSG blued steel. Aluminum and galvanized steel should not be used, since they cannot withstand the high temperatures a wood fire produces. Never use chimney connector pipe as a chimney. You must connect your stove to a chimney like those illustrated in this manual. **DO NOT PASS CHIMNEY CONNECTOR THROUGH COMBUSTIBLE WALL OR CEILING.**

Chimney connector sections must be attached to the stove and to each other with the crimped end toward the stove. This allows creosote to run into the stove and not onto the outside of the pipe. All joints, including transition to chimney connector, should be secured with three sheet metal screws. Otherwise, in the event of a creosote fire, the connector may vibrate apart.

For proper operation, the chimney connector should be as short as possible. Horizontal lengths of chimney connector should have an upward slope from the stove of $\frac{1}{4}$ inch per foot.

Maintain 18 inches clearance between the chimney connector and the wall and ceiling unless a wall protection system is installed.

When installing the stove into a masonry chimney, be sure to check for signs of deterioration and blockage. Once the chimney is determined to be safe, installation can proceed. The size of the flue should also be checked. The chimney must have a fire clay liner or stainless steel lining must be installed. The stainless steel lining should be single wall pipe, 6 inches in diameter, a minimum 24 gauge. If a flue lining is used, an air space between the flue liner and the chimney wall of $\frac{1}{2}$ inch must be maintained.

A list of the more important minimum requirements for a properly constructed chimney follows.

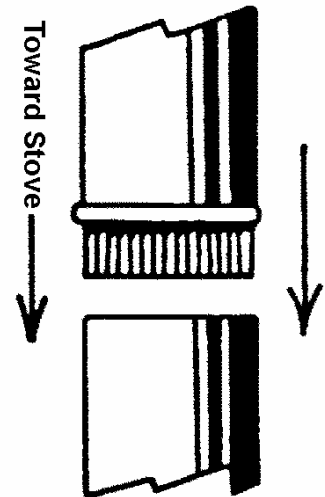

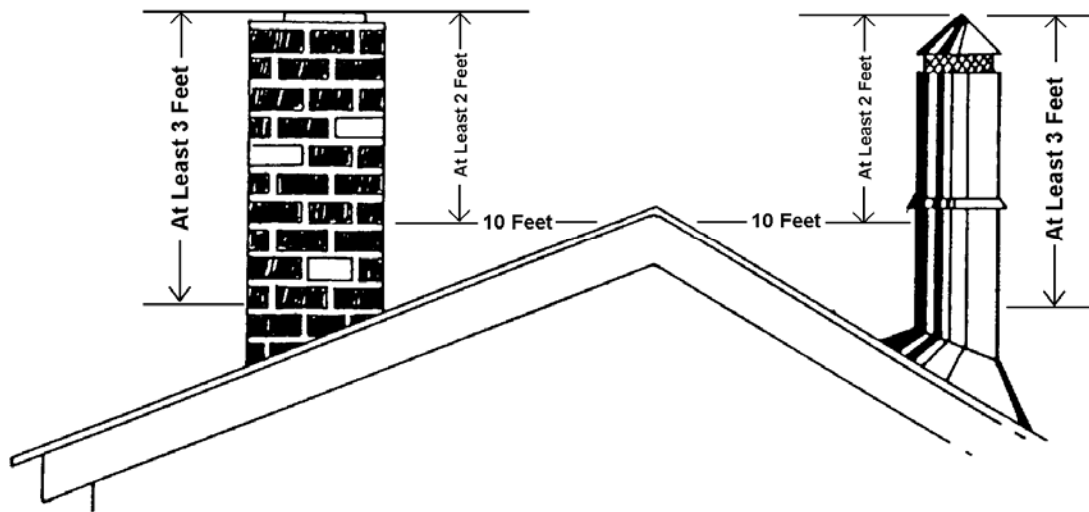

1. For proper operation and safety, the chimney must be at least 3 feet higher than the highest point where it passes through the roof, and at least 2 feet higher than the highest part of the roof or structure that is within 10 feet of the chimney, measured horizontally.
2. Class A chimneys on the outside of the house must have a minimum of one inch clearance to the combustible structure, while a chimney inside the house and through the ceiling must have at least two inches of clearance to the combustible structures. At all points where the chimney passes through floors and/or ceiling, fire stops must be installed. An air space between the chimney and insulation of 2 inches or more must be maintained.

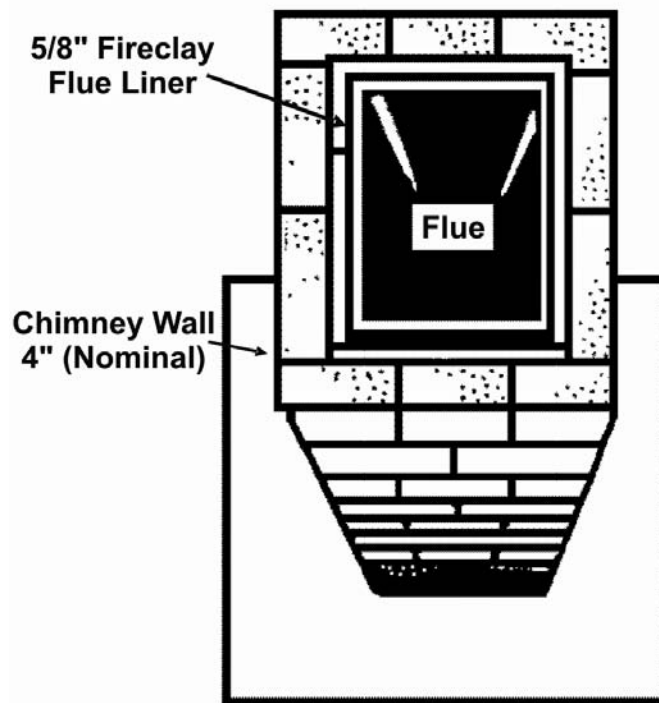

3. The wall of the Class A chimney, if constructed of brick or modular block, must measure a minimum of 4 inches nominal thickness. Mountain or rubble stone wall must be at least 12 inches thick.
4. Installation of single wall pipe from the heater to the masonry flue should rise $\frac{1}{2}$ inch per every one foot of pipe distance from the heater to the chimney.

Firestopping

Remember that insulation must not contact the chimney. There must be air space around the chimney.

Insulation must be 2 inches or more from the chimney.

DO NOT PASS CHIMNEY CONNECTOR THROUGH COMBUSTIBLE WALL OR CEILING. SEE LOCAL BUILDING CODE AND MANUFACTURER'S INSTRUCTIONS FOR PRECAUTIONS REQUIRED FOR PASSING THROUGH COMBUSTIBLE WALL OR CEILINGS.

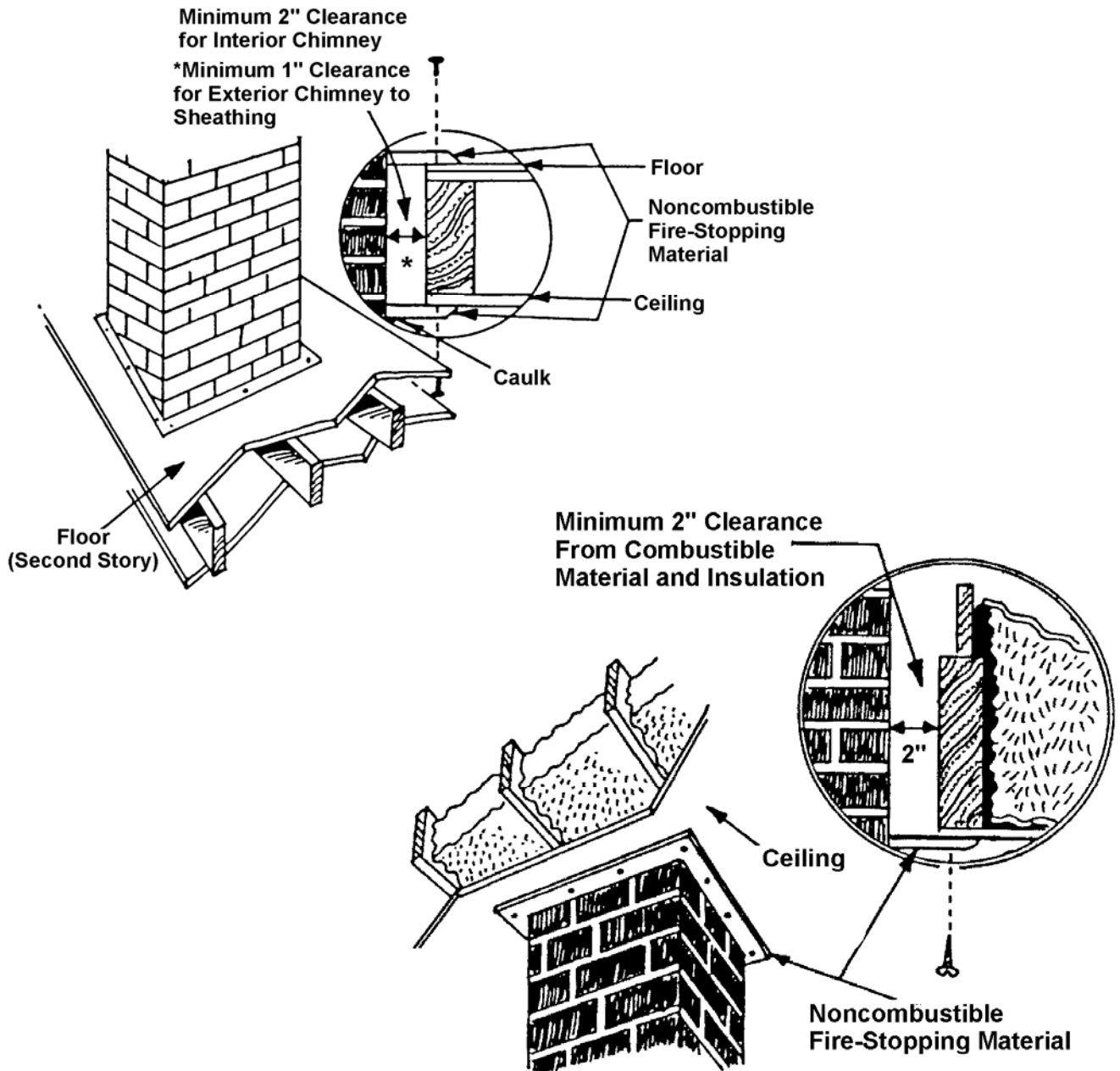

Thimble

When installation entails connection from the stove through a combustible wall to a masonry chimney, a thimble must be used.

Two of several methods of connection through a combustible wall are illustrated below. For alternatives, consult your local building authority or NFPA 211.

Listed prefabricated metal thimbles can be bought for use with woodstoves. The manufacturer's installation for the thimbles must be strictly followed. Maintain all designated clearance to combustible materials.

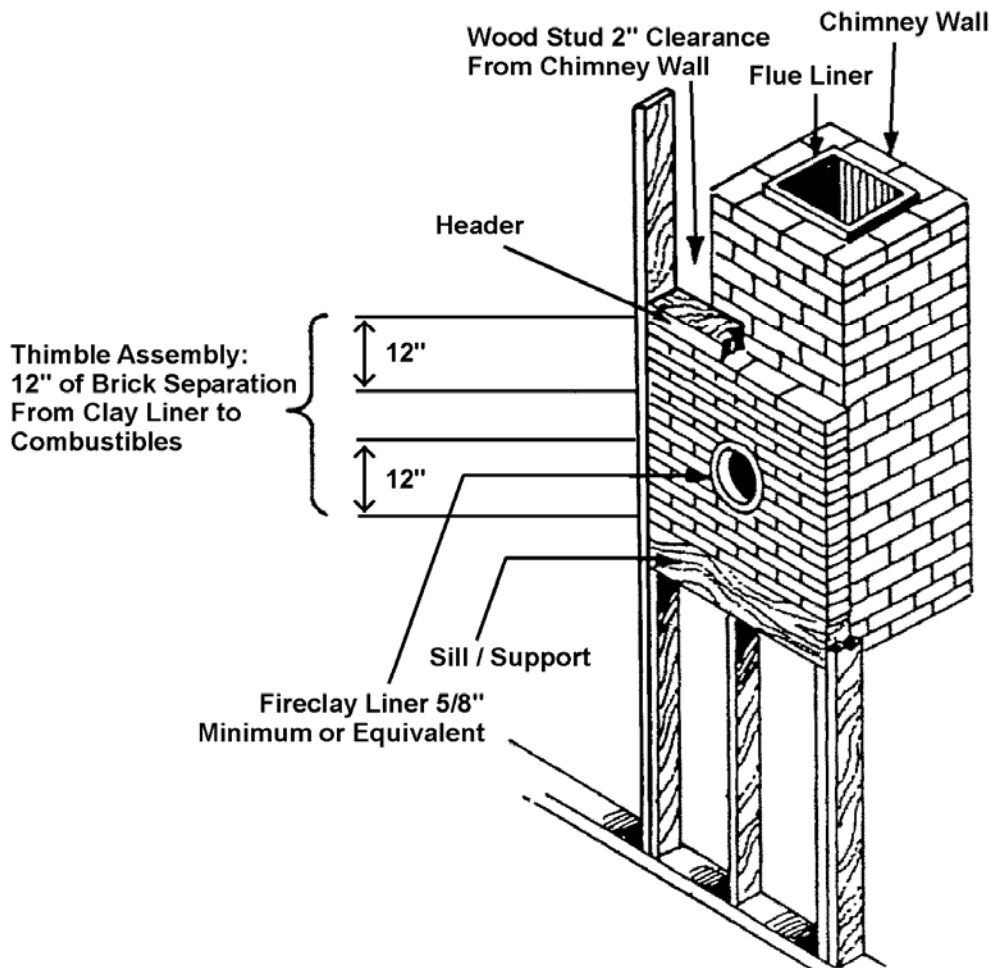

Brick Chimney Thimble Assembly

Construction of the brick thimble assembly requires 12 inches of brick around a fire clay liner. Be sure the point of penetration allows an 18" clearance from the connector to the ceiling. An opening of 32 inches (for a 6-inch chimney connector) must be cut in the wall to maintain the required 12 inches of brick separation from combustibles. It will be necessary to cut wall studs and install a header and sill frame to maintain proper dimensions and to hold the weight of the brick.

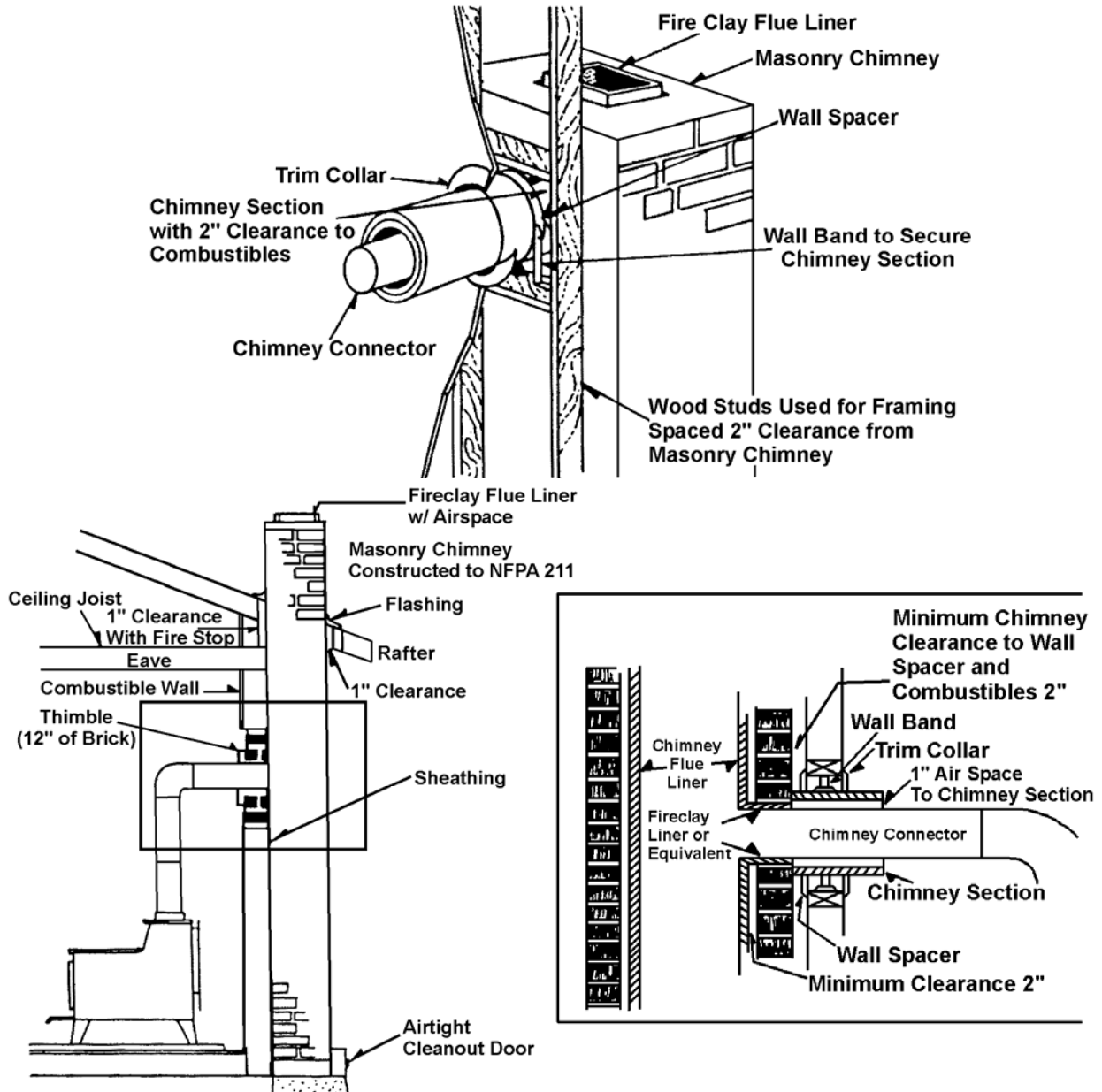

Minimum 3 1/2" (4 inch nominal) thick solid bricks are to be used. The fire clay liner (ASTM C35 or equivalent), minimum 5/8 inch wall thickness, must not penetrate into the chimney beyond the inner surface of the chimney flue liner and must be firmly cemented in place. If it is necessary to cut a hole in the chimney liner, use extreme care to keep it from shattering. Refractory mortar must be used at the junction to the chimney liner. After the assembly is complete, insert the chimney connector in the fire clay liner. Do not push it beyond the inside edge of the chimney liner because this will affect the draw of the chimney.

Install an attic insulation shield to maintain the specified clearance to insulation. Insulation in this air space will cause a heat buildup that may ignite the ceiling joists.

This method of installation requires at a minimum a ceiling support package, an insulation shield and roof flashing.

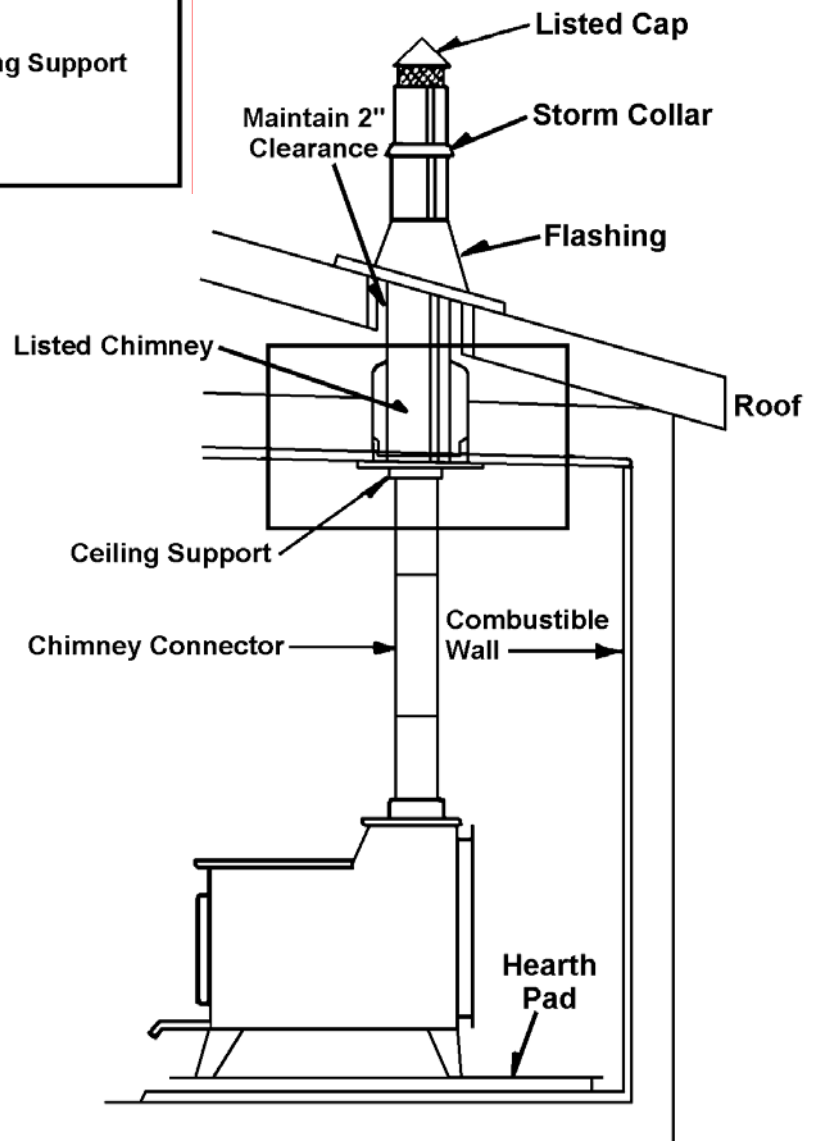
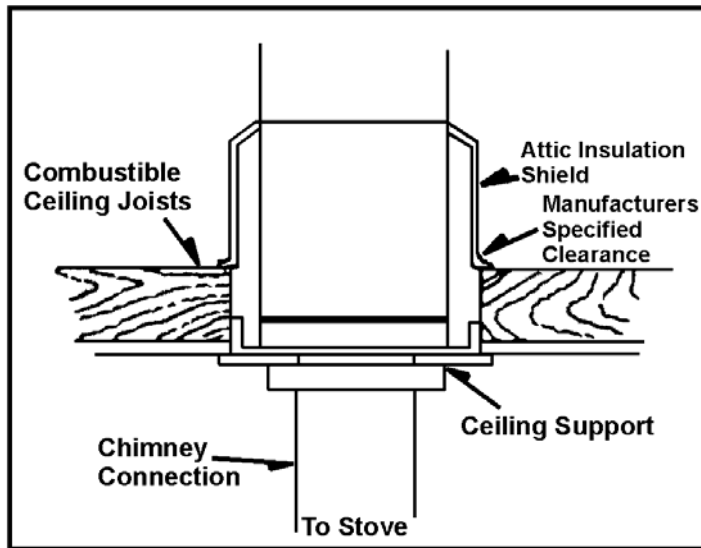

This method of installation requires at a minimum a wall pass through device, a wall support package and insulated "T" section and roof flashing

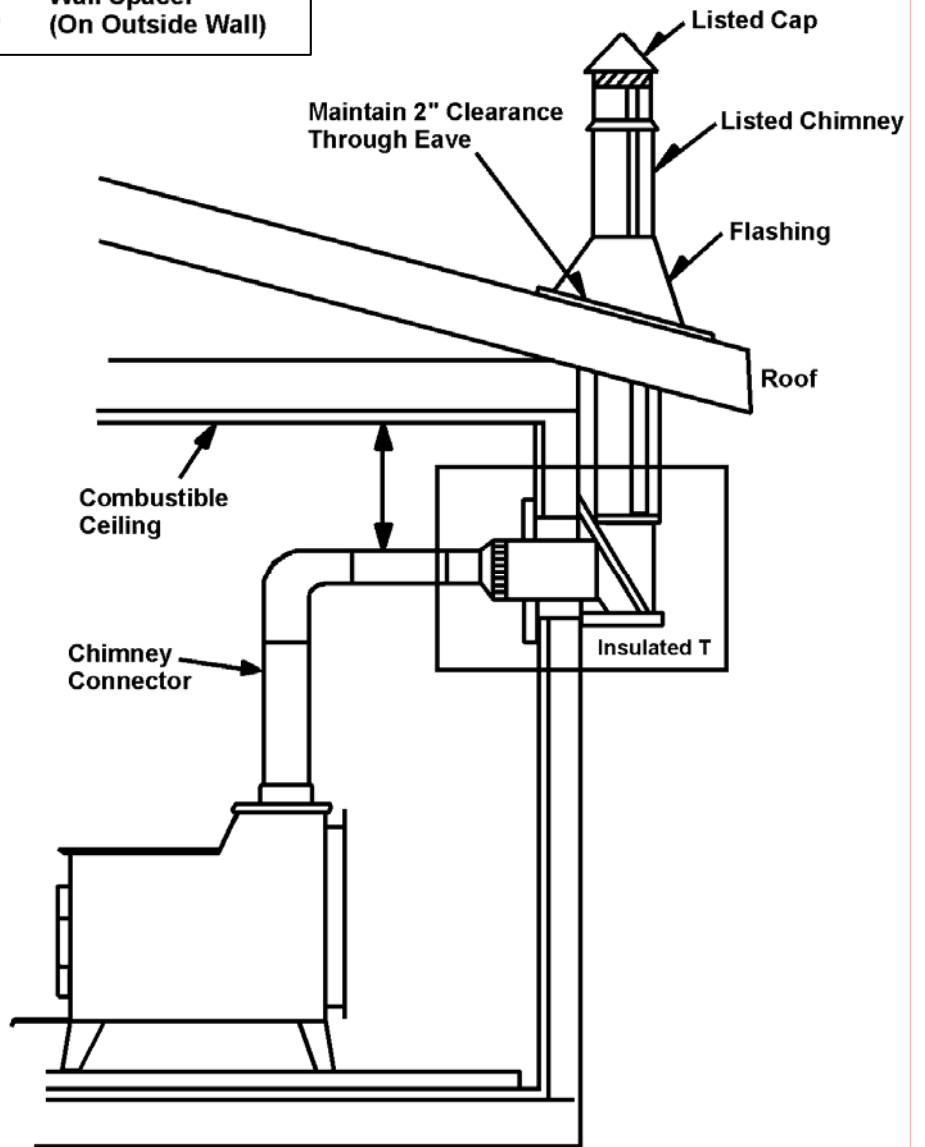
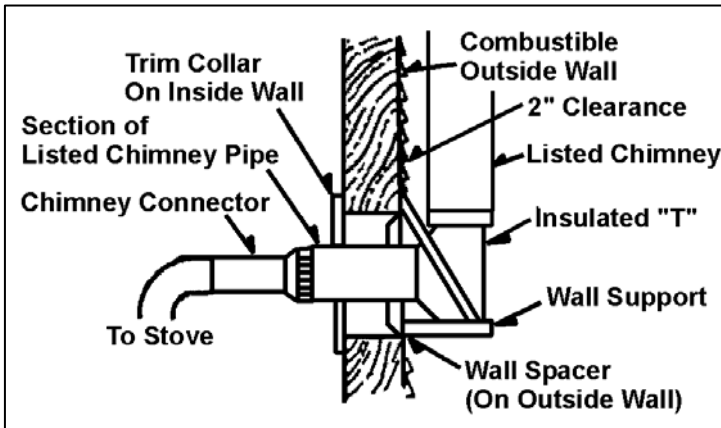

Warnings

This heater is designed to burn natural wood only. Higher efficiencies and lower emissions generally result when burning air dried, seasoned hardwood, as compared to softwood or green or freshly cut hardwoods.

DO NOT BURN

Treated wood
Colored paper
Garbage
Cardboard
Solvents
Coal
Trash

Burning treated wood, garbage, solvents, colored paper or trash may result in release of toxic fumes and may poison or render ineffective the catalytic combustor.

Burning coal, cardboard, or loose paper can produce soot, or large flakes of char or fly ash that can coat the combustor, causing smoke spillage into the room, and rendering the combustor ineffective.

Backpuffing – Smoke from closed fuel door

If smoke enters the room when the fireplace door is closed, check for the following causes:

Proper draft has not had time to establish. Open draft control.
Blockage in the fireplace, stovepipe or chimney.
Leaks in the chimney.
Cold outside chimney.
Chimney is too short.
Chimney is too close to trees or a nearby high roof.

Overfire

Never operate the unit with fuel door or ash pan open.

Do not overfire. Using flammable liquids, too much wood, or burning trash in the fireplace, may result in overfiring. If the chimney connector or fireplace glows red or even worse, white, the stove is overfired. This condition may ignite creosote in the chimney, possibly causing a house fire.

If you overfire, immediately close the fireplace damper and doors to reduce the air supply to the fire. Call the Fire Department immediately. **DO NOT OPERATE THE STOVE AGAIN UNTIL IT IS DETERMINED THAT THE CHIMNEY AND ITS LINING HAVE NOT BEEN DAMAGED AND ARE SAFE.**

Operating Your Energy King

What is a Catalytic Woodstove?

A catalytic combustor is an element which, when used properly in a woodburning appliance, will “burn” smoke, carbon monoxide and particulate which are not burned by the fire. Think of it as an “after burner” which, because of a “catalyst,” chemically breaks down smoke, carbon monoxide and particulate into substances that are burned at a low temperature.

Using Your Catalytic Woodstove

The most important thing to remember when operating a catalytic combustor equipped stove or insert is to make sure you have achieved catalytic light off before you place the unit into the catalytic operational mode. Light off simply means that you have achieved enough temperature within your unit to start the catalytic combustor operating.

Catalytic burning, like all types of burning, requires three essential elements: fuel, oxygen and temperature. The “smoke” is the fuel. The temperature needed to begin catalytic activity is generally 500 to 700 degrees F. This is a temperature that is easily achieved when you build a fresh fire or when you reload your existing fire.

The use of a magnetic thermometer, a probe thermometer, or various digital readouts available on the market today will be of help to you in determining if you have achieved the necessary temperature. The monitor port for the temperature monitor equipment is located 2” to the left of the bypass pull rod.

Your Energy King stove is equipped with a bypass mechanism, located above the door. The bypass allows you to “bypass” the smoke around the combustor when you do not have the necessary 500 degrees to start catalytic activity or when you are reloading your stove. To aid in catalytic light off, coals should be moved aside at the front of the door opening and a tunnel made under the fuel.

The other important thing to remember when operating a catalytic combustor equipped device (or any wood burning device) is to burn seasoned, dry wood only and not to use your wood burning stove or insert as a “garbage incinerator.” A “catalyst” is an element that causes something to happen under conditions by which they would not normally happen, without being consumed or used up by the reaction. In a wood burning appliance, this simply means that the catalyst is allowing the smoke to be burned at 500 to 700 degrees F. rather than the normal 1,100 to 1,200 degrees F. that it would take to burn all elements.

There are elements in garbage, other than dried, seasoned wood that the catalyst will not react with. Some of these elements are lead, sulfur, etc., and as they come in contact with the catalyst, they stick to it, covering it up, so that the elements in wood smoke such as hydrocarbons, particulate and carbon monoxide cannot contact the catalyst and are not burned. This process is referred to as “poisoning”, and after a period, the catalyst is covered and your catalytic combustor will no longer work. How long this process will take to completely cover all the catalyst depends on what you burn in our stove.

Troubleshooting Your Catalytic Combustor

Problem: Creosote accumulation or dirty smoke from the chimney

Possible causes

You are not getting light off in the combustor

You are burning wet wood or improper fuels.

Your bypass mechanism is not fully closing, allowing the smoke to go around the combustor rather than through the combustor.

Solution(s)

Make sure you have achieved 500 degrees F. (necessary for light off) before engaging the combustor.

Burn only dry, seasoned wood.

When the stove is not burning, make sure that the bypass mechanism is closing fully and that there are no obstructions

Replace your catalytic combustor.

Problem: Plugged combustor

Possible causes

You did not achieve light off temperature prior to closing your bypass mechanism and engaging your combustor.

You are burning materials that are coating the catalyst, such as heavy papers, wet wood, garbage, etc.

Your catalytic combustor is no longer functioning and needs to be replaced.

Solution(s)

Make sure you have at least 500 degrees F. (necessary for light off) before you engage the combustor.

Burn only dry, seasoned wood. Lightly brush the face of the combustor with a soft bristle brush, such as a paintbrush, to remove the accumulation. Then build a hot fire in your stove, engage the combustor half way, then two-thirds, then fully to burn the accumulation off the combustor.

Replace your catalytic combustor.

How do I know my catalytic combustor is working?

Ask yourself the following questions. If your answers are **yes**, your catalytic combustor is working properly.

1. Am I burning less wood to get the same amount of heat?
2. Does my combustor glow red for a short amount of the time (approximately 1-1/2 hours) during my wood load?
3. Is there substantially less creosote in my chimney?
4. Is the smoke exiting my chimney white in color and usually odorless?
5. Does a visual inspection of the combustor show it to be clean of any fly ash, creosote or soot?

If the answer to any of the above questions is **no**, the solutions outlined previously may help you to activate your combustor again

Replacing Your Catalytic Combustor

Visually inspect the catalytic combustor at least three times during the heating season to determine if physical deterioration has occurred. Only replace the combustor if it is damaged or no longer operating and use only Applied Ceramics Combustors. (See Applied Ceramics Warranty for information on replacement)

The Energy King fireplace has two catalytic combustors. To replace combustors, look up inside the stove and locate the catalytic combustor retainer plate with holes across its surface. Remove the bolts on each side of the plate and remove the plate. Next, remove the catalytic combustor. Position the replacement catalytic combustors snugly and replace the retainer plate, tightly bolting the plate on both sides.

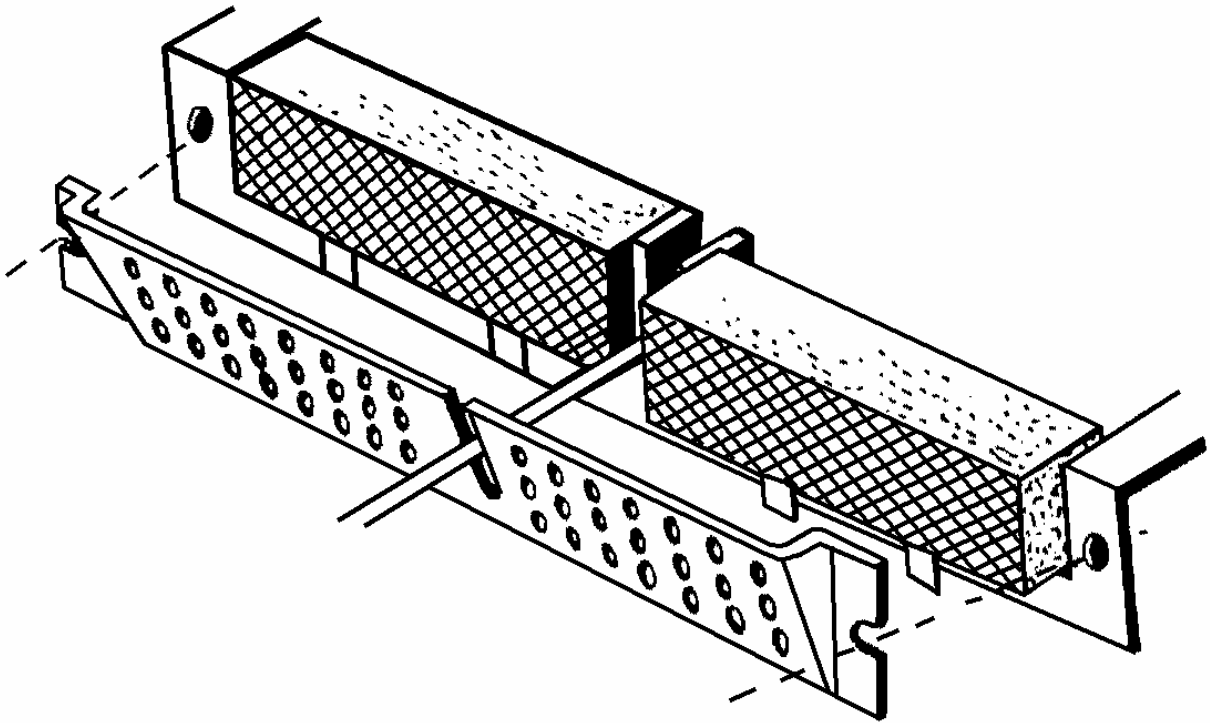

Burning Your Energy King Stove

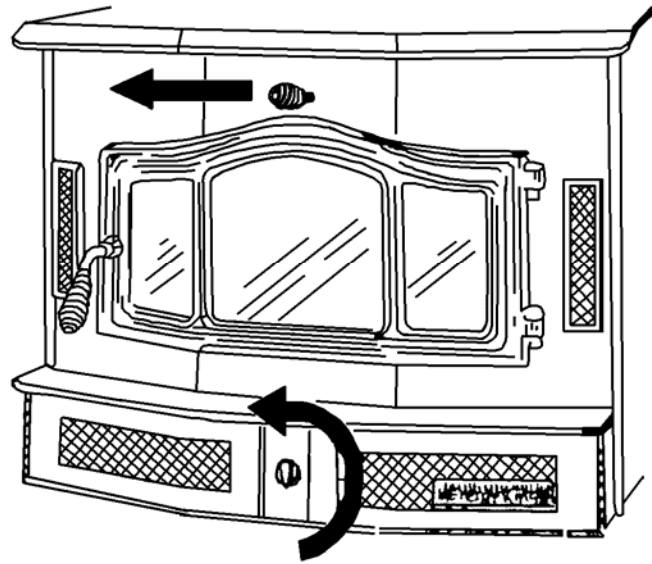

1. Before building a fire, open the bypass, located above the door, to the open position by pulling it all the way out.
2. Open the air control, located above the door, by turning it all the way to the left.
3. Start your fire with paper and kindling on the firebrick refractory hearth. Do not elevate the fire with grates or andirons.
4. Once the fire establishes coals, move the coals aside at the front of the door opening and form a tunnel under the fuel. This will help light off to occur.
5. Add wood to the fire.
6. Continue to burn your fire with the air control fully open for 20 to 45 minutes. This insures that the stove, catalyst, and fuel are all stabilized to proper operating temperature. Even though it is possible to have gas temperatures reach 600 degrees F. within two or three minutes after a fire is started, if the fire is allowed to die down immediately, it may go out or the combustor may stop working. Once the combustor starts working, heat generated in it by burning the smoke will keep it working.
7. After 45 minutes, close the bypass.
8. Close the air control half way for maximum fuel efficiency and burn time.
9. When fueling your Energy King, open the bypass and air control all the way and wait a short time before opening the door. This will eliminate the risk of flame and smoke spillage.
10. Once the stove is fueled, reset the bypass to the closed position, and the air control to medium.
11. During the refueling and rekindling of a cool fire, or a fire that has burned down to the charcoal phase, operate the stove at a medium to high fire rate for about ten minutes to insure that the catalyst reached approximately 600 degrees F.

Operating the Circulating Blower

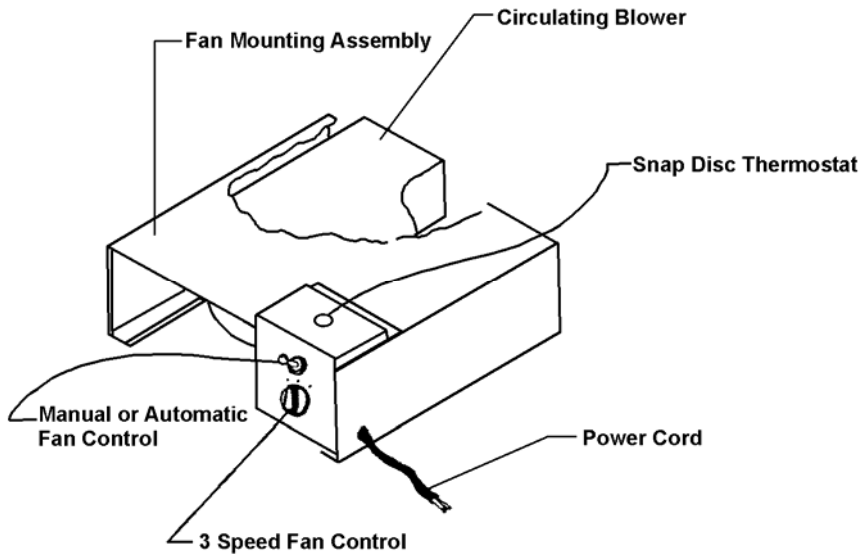

Blower Motor Rating: 115VAC/1.8 AMPS / 60HZ
 Location: Behind cover door on right side of unit front.

WARNING: ROUTE POWER SUPPLY CORD AWAY FROM UNIT. NEVER COVER AIR INLETS ON THE TWO COVER DOORS – Unit front.

The circulating blower operates on 110V., must be plugged into a three prong grounded plug. The blower is controlled by operating a 3-speed switch (high, medium, low). Switch location – bottom of the switch housing inside right cover door.

The fan is operated automatically by a thermostat located on the top of the switch housing. When operating temperature is achieved, the thermostat will automatically turn on the fan to circulate hot air from the air chamber. A toggle switch located on the upper half of the mounting plate will bypass the thermostat and run the fan continuously.

DANGER: RISK OF ELECTRICAL SHOCK – DISCONNECT POWER BEFORE SERVICING UNIT.

Wire Diagram

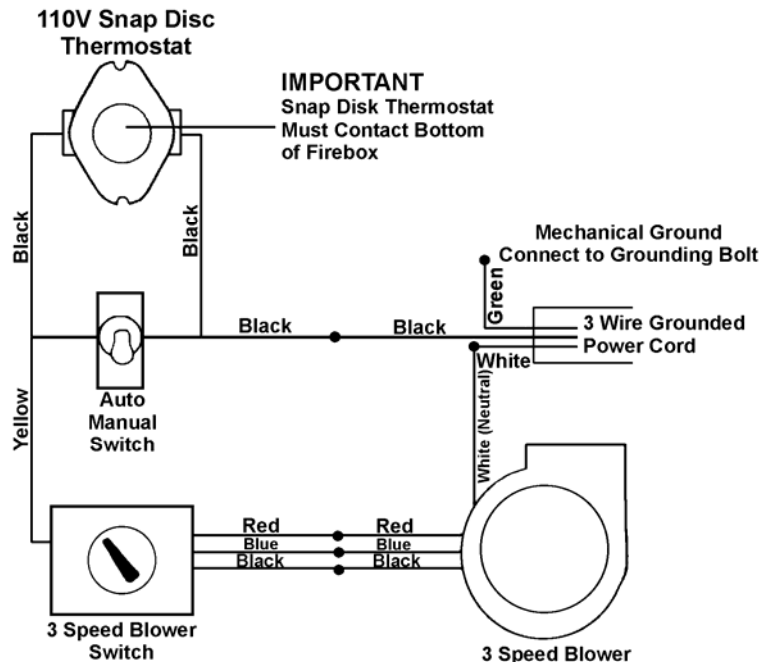

Wood

Choosing the kind of firewood to burn in your stove depends on what is available to you. If all you can obtain is softwoods, obviously, that will be your choice.

Softwoods, such as pine and fir, are easily ignited and burn rapidly with hot flames. However, since they burn so easily and quickly, you will have to spend more time loading your stove, especially in the high burn rate. With softwoods, it will be much more difficult to achieve an overnight burn.

It is best to use more dense hardwoods for a longer lasting fire. It is also a good idea once the fire is established to use larger diameter wood stacked tightly together. This will promote a longer burn time.

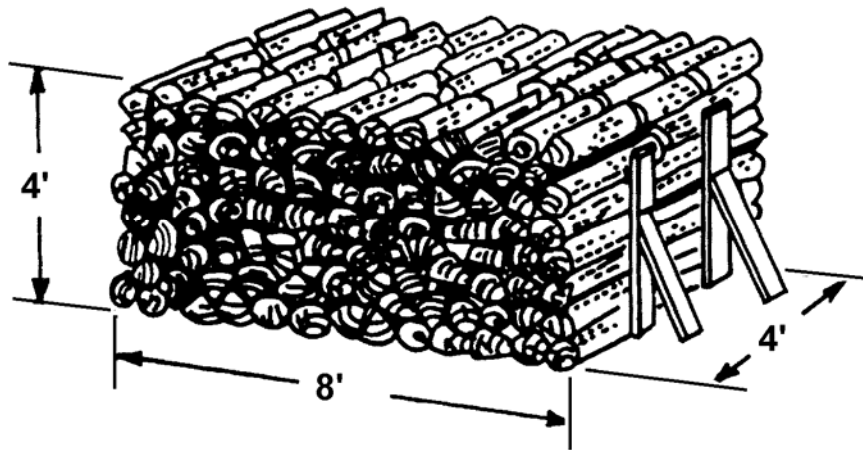

So that you have an idea of how firewood is sold, you should first know that the most common measurement is the standard "Cord." A cord is a nicely stacked pile of wood that measures, 4' x 4' x 8'. ALWAYS look for the driest wood especially if you must purchase wood by weight. Unseasoned, wet wood is much heavier.

If you are going to cut your own wood, plan on drying your wood at least 6 months to 1 year. Stack the wood in such a way as to allow air to circulate through the wood. Wood should be stored in a well sheltered, ventilated area to allow proper drying during the year to come.

Maintaining Your Energy King

At the end of each heating season, clean the chimney. Vacuum out any ash accumulation. Replace any worn gaskets or broken firebrick.

Disposal of Ashes

The ash pan is located in the left bottom access door. To remove ash pan, turn locking lever to the left and pull out. Ashes should be removed year round and stored in a fireproof metal container with a tight fitting lid. The container should be kept on a non-combustible floor or on the ground, well away from all combustible materials, until all cinders have thoroughly cooled. If the ashes are disposed of by burial in soil or otherwise locally dispersed, they should be retained in the closed container until all cinders are thoroughly cool. An accumulation of too much ash restricts airflow and reduces the available burning area. A ½" to 1" layer of ash should be maintained, however, to support combustion and insulate the bottom of the firebox. Be sure to lock ash pan in place by turning locking lever to the right.

Creosote – Formation and Need for Removal

When wood is burned slowly, it produces tar and other organic vapors, which combine with expelled moisture to form creosote. The creosote vapors condense in the relatively cool chimney flue of a newly started fire or from a slow burning fire. Therefore, creosote residue accumulates on the flue lining. When ignited, this creosote makes an extremely hot fire that may damage the chimney or even destroy the house.

The chimney connector and chimney should be inspected at least twice monthly during the heating season to determine if a creosote buildup has occurred. If creosote has accumulated, it should be removed to reduce the risk of a chimney fire.

Inspect the system at the stove connection and at the chimney top. Cooler surfaces tend to build creosote deposits quicker, so it is important to check the chimney from the top as well as from the bottom.

Creosote should be removed with a brush specifically designed for the type of chimney in use. A chimney sweep can perform this service. It is also recommended that before each heating season, the entire system be professionally inspected, and cleaned and repaired if necessary.

Care of Glass

Your Energy King is equipped with a super heat resistant glass, available through your Energy King retailer. The glass can only be broken by impact or misuse. Never slam the door or impact the glass. When loading fuel, be sure logs don't touch the glass.

In case of breakage, glass must be replaced with a high temperature glass such as Robax. Tempered or ordinary glass will not withstand the high temperatures of the Energy King fireplace. Do not operate the unit with cracked or broken glass. Replacement glass should be purchased from your Energy King retailer or RJM Manufacturing, Inc. To remove the broken or damaged glass panel, remove the glass retaining clips and carefully remove the glass panel. Insert the replacement glass and attach the glass retaining clips.

The glass should be cleaned with a non-abrasive glass cleaner. Abrasive cleaners may scratch and cause the glass to crack. **Do not clean the glass when it is hot.**

Care of Gold Plated Door

A household glass cleaner and a soft cloth should be used to clean the gold-plated door. **Do not clean the door when it is hot.**

Care of Blower

CAUTION: MOVING PARTS MAY CAUSE INJURY. DO NOT OPERATE UNIT WITH COVER PLATE REMOVED.

The blower assembly can be easily removed by following these procedures: Disconnect power, remove the clamping bolt located under the blower assembly, and pull out approximately 4". Remove the wire nuts that connect the power cord. (Black, white and green wire.) Clean the motor and blower wheel by vacuuming away any dust or dirt. Place unit back into the opening, connect wires (black-to-black, white-to-white, green-to-mechanical ground.) Place unit in the rest of the way to the back fan stop. Check to be sure wires are not cut or connections have not become loose. Place clamp bar over bolt and tighten down. Connect power cord. Unit should now be ready to operate.

Gasket Replacement

Door and glass gaskets need to be replaced on an annual basis to insure that the stove remains airtight. Failure of the door or glass gaskets will allow additional air to enter the stove and drastically decrease the burn time of your fuel.

To check for gasket failure, start a fire in the stove. Once you have a well established fire, damper the stove down. Next take a lit match and direct it along the edge of the door and stove. Do the same along the inside edge of the door and glass. If you notice the flame from the match being drawn to the gap, there is an air leak in the gasket and it needs to be replaced.

Door Gasket. To replace the door gasket, simply remove the door and lay it face down on a clean soft surface, such as a towel. Find the ends of the gasket and pull it off. Take a screwdriver and remove excess gasket glue from the channel. Take new stove gasket cement (available at your local woodstove retailer or hardware store) and lay a medium to heavy bead around the gasket channel. Take the new door gasket (also available at your local woodstove retailer or hardware store) and lay it in the channel. Cut off any excess gasket rope. Reattach door and seal. Leave the door closed until the gasket cement dries.

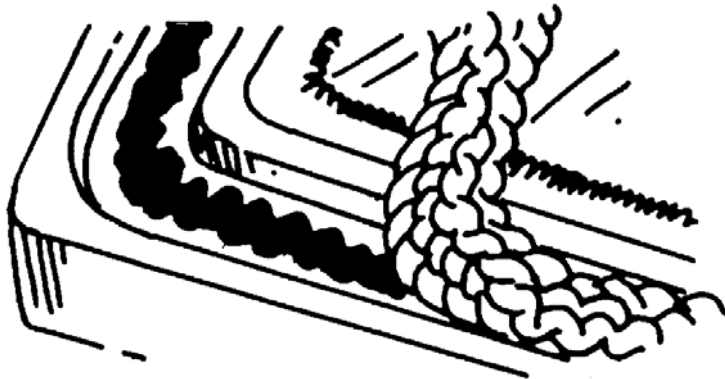

Glass Gasket. To replace the glass gasket, remove the glass retaining clips along the inside of the stove door. Remove the glass. Remove the old gasket by pulling it off. Take the new gasket (available at your local woodstove dealer) and peel off the protective paper. Place the new gasket around the edge of the glass. Trim off any excess gasket. Replace glass and clips.

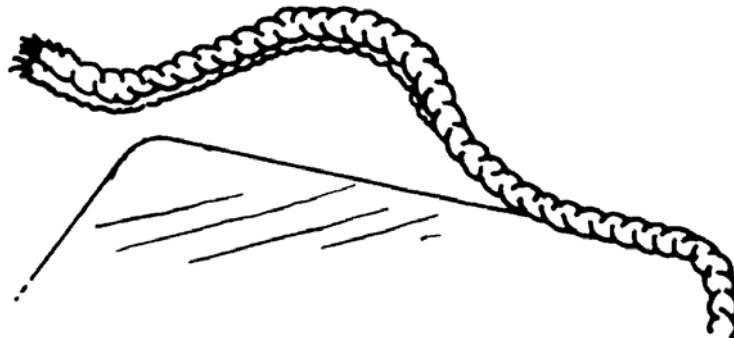

Troubleshooting Guide

Unit does not burn properly

1. Check the wood; it must be dry. If moisture is sizzling out the end, the wood is too wet.
2. Test the draft. It should be .05/.06 (inches of water column).
3. Check to make sure the flue is not obstructed. Also check the baffle area in the unit for excessive ash buildup.
4. Check the airflow in the room. If it is too air tight, the unit cannot get enough combustion air to burn properly. You may need to bring outside air to the furnace or stove.
5. Check the chimney and stovepipe. They need to be air tight to make the unit draft properly.
6. Check that only one appliance is hooked to the chimney.
7. Check the chimney for a downdraft. A cold chimney will keep flue gases from rising up the chimney. Proper insulation of chimney and/or installing a stainless steel liner sized for the unit may remedy the problem.
8. Check your chimney for downdraft caused by taller surrounding trees or buildings. The chimney may have to be extended or a chimney vent cap installed.
9. Check all gaskets for leaks: Door gaskets, glass gaskets, ash drawer or door gaskets (where applicable).

Unit does not give off enough heat

Is the unit installed correctly?

1. Check to see if the unit has an adequate cold air return or inadequate hot air outlet.
2. Room may be too air tight, inadequate combustion air or return air.
3. Flue draft may be inadequate or too strong - .05/.06 (inches of water column) recommended.
4. Door gaskets may be leaking. In addition, glass gaskets, ash drawers or door gasket should be checked for leakage.
5. Check flue. Make sure it is not obstructed.
6. Check ductwork for leaks, cold and hot air ducts.

Unit is making noise/distribution blower is vibrating

With electrical power disconnected, check the following:

1. Check for loose parts.
2. Is the blower wheel contacting the housing? If so, realign or replace as required.
3. Is foreign material inside the housing?
4. Is there a leak in the ductwork or is there loose ductwork?
5. Does the blower wheel/motor need to be cleaned or serviced?
6. Is the blower wheel set screw loose? If so, secure it properly.

Maintenance of blower assembly

After disconnecting the power source,

- a) Remove dirt from blower wheel and housing.
- b) Check tightness of wheel set screw.
- c) Check the wiring to see if it is secure and well insulated.
- d) Lubricate the motor according to the manufacturer's instructions. Remove any excess lubricants.

Blower is not working

1. Check for blown fuse or open circuit breaker.
2. Insufficient air flow
 - a) Motor speed is too low (multi speed units only).
 - b) Leaks in ductwork.
 - c) Dampers and/or registers closed.
 - d) Obstruction in system
 - e) Clogged filters
3. Too much air flow
 - a) Filters not in place (where applicable).
 - b) Motor speed too fast (multi-speed units only).
 - c) Registers or grills not installed.
 - d) Insufficient static pressure (SP). Check your static pressure (SP) calculations and correct system accordingly.
4. Motor overloaded - System static pressure too low. Check and correct system.
5. Thermostat is not opening damper (or turning on forced draft fan)
 - a) Check wall thermostat.
 - b) Check the thermostat wires (possible short or broken wire).
 - c) Check wire connections.
 - d) Make sure heated area is calling for heat.
 - e) Check damper assembly so that all parts move freely.
 - f) Damper motor or forced draft fan improperly wired – compare wiring on the unit to the schematic in the manual.
6. Excessive creosote
 - a) Make sure the units smoke pipe is vented into its own proper chimney.
 - b) Check length of flue pipe and all connections. Offsets in flue pipe will slow flue gases down causing buildup.
 - c) Slow fires with excessive amounts of fuel can cause creosote buildup in smoke pipe and chimney.

Use and Maintenance of a Catalyst

1. Do not “Hot Fire” the stove. For many years, retailers and installers have advised customers to build an extra hot fire to burn the creosote deposits in the flue system. This advice may be acceptable for non-cat stoves, but can be death to a catalyst. Why? Because the catalyst is reducing the particulate, or creosote buildup, therefore, the need to Hot Fire is eliminated. Also, see point #2.
2. Direct Flame contact is death to a catalyst. A catalyst burns the byproducts in the smoke. The gases such as CO, HC, and O₂ ignite with each other in the presence of the catalyst, (while passing through the honeycomb configuration). This is a chemical reaction. Direct flame inhibits this reaction by changing the chemical makeup of the catalyst. The flame also breaks down the substrate or ceramic. This problem is called flame impingement. Today’s modern stoves are designed so that flame impingement is unlikely. However, a strong, fast draft can pull the flame into the catalyst. Or a “hot fire,” with all the air controls and/or the ash door open, can literally torch the catalyst. Controlling the draft also can reduce fly ash problems.
3. The “Glow” misconception: A catalyst can glow during certain stages of combustion. The determination that a catalyst is not working simply because it does not “glow” is inaccurate. During the low burn cycle, when the catalyst is doing the bulk of its work, it usually does not glow. Also extremely dry wood (oak, ash, etc.) can burn clean enough not to produce a glow in the converter.
4. Light off Temperature: CO conversion in the Applied Ceramics catalyst begins at a very low temperature. Usually a normal startup to produce a coal bed will produce more than sufficient temperatures to begin catalytic combustion.
5. The catalyst is not consumed or “used up”. The nature of a catalytic reaction is defined as follows, by The American Heritage Dictionary, Second College Edition:

Cat.a.lyst n. 1. Chem. A substance, usually present in small amounts relative to reactants, that modifies and especially increases the rate of a chemical reaction without being consumed in the process.
6. Why does a catalyst stop working? Most catalysts that are returned either are destroyed by flame impingement, broken due to accidents or mishandling, or have nothing wrong with them but fly ash buildup.

A catalyst can be “saturated” with byproducts of wood burning such as potassium. This is chemical saturation. The prohibitive chemical will fill in the chemical “holes” that the gases normally use for reaction. This process of “saturation” can be slowed by regular maintenance of the catalyst. “Saturation” can take several years. Burning garbage, painted woods, or large amounts of colored paper can poison your unit. Poisoning however is very difficult to do. Burning colored paper causes more of a fly ash problem than a risk of poisoning. NEVER BURN RUBBER OR PLASTIC.

When a catalyst has ceased to be effective, you will notice increased fuel usage and your chimney sweep will notice increased creosote in your system. Before you replace the unit, review this sheet. If you find that your catalyst should be replaced, follow the instructions for warranty replacement that were provided when your unit was purchased.

Cleaning the catalyst with plain water can reduce buildup of the catalyst - retarding chemicals. Nothing but a soft brush, low-pressured air or plain water should be used to clean a catalyst. The ceramic unit is fragile in comparison to the rest of the stove – so it should be handled with care. A soak in warm or hot (not boiling water) for 20 minutes is ideal. Then allow the unit to cool at room temperature and rinse under medium pressure under a faucet. Allow the unit to thoroughly dry before reinstalling it or you will damage it. Then reinstall the unit according to the stove maker’s or retrofit manufacturer’s instructions. A cleaning once every year is sufficient for most users. Clean it when you have your flue system cleaned.

Frequently asked questions

- Q. "How can I tell if I am operating my woodstove properly?"
- R. Check the exhaust coming out of your woodstove chimney. The smoke is your operational barometer. If your fire is burning properly, you should only see the white transparent steam of evaporating water, darker and opaque smoke will only be slightly visible. The darker the color of the exhaust, the less efficiently you are operating the appliance. It may be necessary to adjust the operation of your woodstove to decrease the opacity of the exhaust (that is, the density of the smoke).
- Q. "Once I have preheated my chimney, how should I operate the stove?"
- R. Although all woodstoves require preheating during startup and reloading, their operation afterwards vary somewhat. Woodstoves that use catalytic combustors require the monitoring of temperatures and air supply to ensure that the catalyst engages at appropriate times in the combustion cycle. Generally, catalytic stoves require lower combustion temperatures in the firebox to burn cleanly. At 500-1000 degrees F., the catalyst ignites, burning the volatile gases and particulate. Noncatalytic stoves attain much higher temperatures in the combustion path before the gases and particulate burn. Always refer to your woodstove manufacturer's operation manual and follow the instructions for your particular make and model.
- Q. Do I operate my stove differently in cold vs. warm weather conditions?"
- R. Yes, during the warmer seasons of spring and fall, control the total heat output by limiting the amount of fuel (wood) rather than by closing down the air supply. Make shorter, hot fires using more finely split wood. The actual air supply setting will vary according to your stove instructions, but the fuel loadings will be consistently smaller. Let the fire burn out rather than smolder at low air supply settings. When your home requires more heat, restart the fire with kindling as always, but add smaller fuel loads. This allows your stove to operate at maximum efficiency and with minimum emissions. Avoid the temptation of building a big fire and then starving it for air.
- Q. "Is it important to have my stove and chimney cleaned?"
- R. Smoke rising through your chimney may condense and build up on the cooler inside walls forming a substance known as creosote. This volatile substance can ignite and burn in the chimney. Many chimneys and installations are unable to withstand these dangerous creosote fires; the results can be tragic.
- Q. "How often should I have my chimney inspected and cleaned?"
- R. A professional, certified chimney sweep should inspect and clean your flue system regularly. Frequent stove use may require monthly chimney inspection and cleaning while even minimal use will require annual servicing.
- Woodstove connectors (stovepipes) should be checked as often as every 2-4 weeks. Your chimney sweep can show you the proper methods for these more frequent inspections.
- Q. "Does it matter what kind of wood I use?"
- R. Your fuel supply should consist of a mixture of hardwoods, like maple or oak, and softwoods, such as fir and pine. When first starting your fire, use softwoods. They ignite easily and burn rapidly with a hot flame. Hardwoods provide a longer lasting fire and are best used after preheating the chimney. If hardwoods are unavailable, you can control your fire's burn rate by using larger pieces of wood.

- Q. "Is it important to season wood before burning it?"
- R. The seasoning, or drying, process allows most of the natural moisture found in wood to evaporate, making it easier to burn. A properly seasoned log will have 20%-30% moisture content.

Wood only dries from the surface inward; unsplit pieces dry very slowly. To properly season wood, split the logs as soon as possible and stack them in a dry spot for 6-18 months. Pile the wood loosely, allowing air to circulate through the split logs. Hardwoods take longer to dry than softwoods. Humidity and temperature levels also will impact drying time.

- Q. "What's the best way to load wood into my stove?"
- R. Avoid placing pieces of wood in parallel directions, where they may stack too closely. Vary the position of the wood in the firebox to maximize the exposed surface area of each piece of wood. Only use wood properly sized for your stove's fire chamber. Complete wood combustion requires wood (fuel), temperature (heat), and oxygen (air) to burn completely and cleanly.
- Q. "Is there anything I shouldn't burn?"
- R. Never burn garbage, plastic, foil, or any kind of chemically treated or painted wood. They all produce noxious fumes that are dangerous and highly polluting. Additionally, if you have a catalytic stove, the residue from burning plastics may clog the catalytic combustor.
- Q. "When installing a woodstove, what's the first thing I should consider?"
- R. The woodstove and chimney work as a system. It is important that the stove's chimney system be sized properly, according to the manufacturer's instructions. Whether venting into a masonry or metal system, make sure the diameter of the chimney matches closely, but never smaller than, the size of the stove's flue outlet. Doing anything else adversely impacts emissions and safety.
- Q. "Can I install my own stove, or should I have the installation done professionally?"
- R. Preferably, a certified professional should install your stove. More than likely, this technician is familiar with your model and has installed many others like it. This experience can save you time, money and frustration in the long run. Plus, it gives you the confidence that your stove is installed properly and safely.

For owners who choose to install their own woodstoves, follow the manufacturer's instructions explicitly. **NEVER** proceed without professional advice if you have a question.



ENERGY KING BAY 2000C LIMITED WARRANTY

Who is covered?

You are covered under this warranty if you are the original purchaser of a new **ENERGY KING** solid-fuel heating appliance and your purchase was made through an authorized distributor/dealer of the **ENERGY KING** solid-fuel heating appliance.

How long does the coverage last?

The term of this warranty begins on the date of original purchase as evidenced by your purchase receipt, subject to the terms, conditions and restrictions of this agreement. Coverage is extended to you for the following time periods:

- **Burn chamber.** The burn chamber is warranted for five (5) years on a prorated basis. The replacement value will decrease each year until the maximum life of the warranty exhausts any replacement value. Replacement value is reduced 20% per year and will be calculated on the cost of the burn chamber at the time the part is repaired or replaced. We will provide you with a credit to be applied towards the cost of the repair or replacement part.
- **Castings.** The castings are warranted for one (1) year and include, but are not limited to, the fuel loading door, ash grate, flame grate, pipe connectors, and side vents.
- **Electrical Components.** The electrical components are warranted for one (1) year and include, but are not limited to, the circulation blower, snap disc thermostat, power cord, and three-speed switch.

What is covered by this warranty?

This warranty covers any defects in materials or workmanship in your new **ENERGY KING** solid-fuel heating appliance.

What is not covered by this warranty?

This limited warranty does not apply:

- If your appliance has not been installed, operated and maintained in strict accordance with instructions provided in the Installation, Operation and Maintenance Manual.
- If any part has been damaged in shipment, modified, altered, tampered with, abused, or has been subject to accident or misuse.
- If your appliance has been altered or repaired in a manner which, in our sole judgment, affects its performance, stability or reliability.
- If parts not made or supplied by us have been used in connection with the appliance, if in our sole judgment, such use affects its performance, stability or reliability.
- To transportation charges on appliances and appliance parts submitted for repair or replacement under this warranty.
- To expendable, replaceable or wear items, such as firebrick, gaskets/seals, paint, handles and other items that in our judgment are expendable, replaceable or wear items.
- To any heating system or systems to which the appliance may be attached.
- To any of the smoke pipes, heat pipes, chimney, hardware, ducting, vents, or other accessories used for the installation and venting or ducting of the appliance.

We are not responsible for installation and will not be liable in any respect under the terms of the warranty for injury or damage to the building structure in which the appliance has been installed, or to the person or persons and property therein, arising out of the use, or installation of the **ENERGY KING** appliance. The appliance must be installed in compliance with the local, state and national building and fire codes and regulations of the area and in strict adherence to the Manufacturer's recommendations.

What will we do to correct problems?

We will repair, or at our option, replace any **ENERGY KING** solid-fuel heating appliance or appliance part, which upon inspection shows a defect in materials or workmanship.



How can you get service?

If warranty service is needed during the warranty period, notify your authorized **ENERGY KING** dealer. If there is no **ENERGY KING** dealer in your area, contact RJM Manufacturing, Inc. directly. Provide your name, address, phone number, serial number and model number of the Fireplace, date of purchase, name and address of installer and a description of the problem.

Disclaimer of Implied Warranties & Consequential Damages

Our obligation under this limited warranty, to the extent allowed by law, is in lieu of all warranties, implied or expressed, including implied warranties of merchantability and fitness for a particular purpose and any liability for incidental and consequential damages with respect to the sale or use of the items warranted. Such incidental and consequential damages shall include but not be limited to: transportation / freight charges, cost of installation, duty, taxes, charges for service or adjustment, loss of income, rental or substitute equipment, and expenses due to loss, damage, detention or delay in the delivery of equipment or parts resulting from acts beyond our control.

Some states do not allow the exclusion or limitation of incidental or consequential damages, or limitation of implied warranties, so the limitations or exclusions in this limited warranty may not apply to you.

NO EMPLOYEE OR REPRESENTATIVE OF RJM MANUFACTURING, INC. IS AUTHORIZED TO CHANGE THIS LIMITED WARRANTY IN ANY WAY OR GRANT ANY OTHER WARRANTY UNLESS SUCH CHANGE IS MADE IN WRITING BY AN OFFICER OF RJM MANUFACTURING, INC. AT ITS HOME OFFICE.

YOUR RESPONSIBILITY UNDER THE WARRANTY

It is your responsibility to ensure that the appliance is installed in compliance with local, state and federal building and fire codes regulating installation and inspection.

It is your responsibility to complete the warranty card and return it to the address indicated within 30 days of the purchase. You must also keep your receipt as proof of date of purchase. Failure to do so will mean that you may not later make a claim under this warranty.

It is your responsibility to read the Installation, Operation & Maintenance Manual and to install, operate and maintain the appliance in accordance with all instructions and safety procedures. Failure to do so is a misuse of the appliance.

It is your responsibility to inspect the appliance and to have any part(s) repaired or replaced when continued operation would cause damage or excessive wear to other parts or cause a safety hazard.

It is your responsibility for any cost incurred by the distributor/dealer for travel to or transportation of the product for the purpose of performing a warranty obligation or inspection.



RJM Manufacturing, Inc.
1875 Olson Drive
Chippewa Falls, WI 54729
(715) 720-1794 ♦ Fax (715) 720-1797
Email: sales@energyking.com
www.energyking.com

APPLIED CERAMICS *VERSAGRID* CATALYTIC CONVERTER

LIMITED LIFETIME WARRANTY

APPLIED CERAMICS warrants to the consumer who purchases a ***Versagrid Catalytic Converter*** as a component in an E.P.A. certified solid fuel appliance, to replace at no charge to the consumer the ***Versagrid Catalytic Converter*** that ceases to function within three (3) years from the date of purchase by the original consumer, provided that the following conditions are met:

1. A copy of the original bill of sale that includes place and date of purchase must be submitted with the warranty claim.
2. The original ***Versagrid Catalytic Converter*** must be returned to APPLIED CERAMICS.
3. The ***Versagrid Catalytic Converter*** must not have been mechanically abused, nor must the wrong fuels have been used on the appliance.

If after three years, the ***Versagrid Catalytic Converter*** fails to function, the prorated warranty will allow replacement at the following special price schedule:

Year 4	\$85.00
Year 5	\$95.00
Year 6	\$105.00
Year 7 and after	– at current retail price

Conditions 1, 2, and 3 also apply to the Prorated portion of the warranty.

Any E.P.A. certified solid fuel appliance will receive one replacement catalyst for each defective catalyst returned during the three year period. The consumer will be responsible for removal, any servicing, and return of any items required for filing the warranty claim. This warranty is APPLIED CERAMICS exclusive warranty and APPLIED CERAMICS disclaims any other express or implied warranty for the ***Versagrid Catalytic Converter***, including any warranty or merchantability of fitness for a particular use.

All warranty claims must include \$10.50 for postage and handling. Please allow 2 – 3 weeks for delivery. Order online at www.appliedceramics.com and save 10%.

Mail Address:
Applied Ceramics
Customer Service Department
PO Box 29664
Atlanta, GA 30359

UPS Address:
Applied Ceramics
Customer Service Department
5555 Pleasantdale Road
Doraville, GA 30340

Telephone: (770) 448-6888